



Electric Service Requirements

Customer-Built Vaults Engineering Specification T001

August 2021



 SMUD [®]	ENGINEERING SPECIFICATION	No. T001 Page 1 of 35	
		REV. 10	DATE: 8/21
CATEGORY <p style="text-align: center;">ELECTRIC SERVICE REQUIREMENT</p>			
SUBJECT <p style="text-align: center;">Customer Built Vaults</p>			

Table of Contents

1	Purpose	1
2	Scope	1
3	References	1
4	Definitions	2
5	Vault Location	3
6	Minimum Vault Dimensions	3
7	Vault Design	5
8	Inspection	26
9	Submittals	28
10	Standards and Codes	30
11	Permits, Licenses and Bonds	30
12	Appendix A: List of Material Suppliers	31
13	Appendix B: Design and Construction Drawings	34

 SMUD ENG. SPEC. T001	REV. 10	CUSTOMER-BUILT VAULTS	page 1 of 35
---	------------	------------------------------	-----------------

1 Purpose

This specification provides the minimum requirements of the Sacramento Municipal Utility District's (SMUD) design and construction of customer-built transformer vault(s), which will be used to house SMUD's equipment and materials.

This specification is *NOT* a complete design or construction specification. Compliance with this specification, all SMUD applicable specifications and all local agencies having jurisdiction is a requirement for service.

2 Scope

This Engineering Specification outlines SMUD's minimum requirements for SMUD customer transformer vaults. The customer shall supply all labor, material(s) and resources necessary to meet or exceed all SMUD's and applicable local agency requirements for the vault design and construction.

This specification shall apply to all transformer vaults; new construction and renovation.

3 References

The latest revisions of the following references apply to this Engineering Specification.

- 3.1 California Electrical Code (CEC), Latest Revision.
- 3.2 National Electric Code (NEC), Article 450, Transformers and Transformer vaults.
- 3.3 CAL-OSHA General Industry Safety Order #3277 – Fixed Ladders.
- 3.4 ASTM A123, Standard Specification for Zinc (Hot Dipped Galvanized) Coatings on Iron and Steel Products.
- 3.5 ASTM A153, Standard Specification for Zinc Coating (Hot Dip) on Iron and Steel Hardware.
- 3.6 Metal Framing Standards Publication, No. MFMA – 4.
- 3.7 ASTM A276, Standard Specification for Stainless Steel Bars and Shapes Type 316 – Round bar (Solid).
- 3.8 ASTM A276, Standard Specification for Stainless Steel Bars and Shapes Type 316L (If Welding is Required).

 SMUD ENG. SPEC. T001	REV. 10	CUSTOMER-BUILT VAULTS	page 2 of 35
---	------------	------------------------------	-----------------

- 3.9 ASTM A240, Standard Specification for Chromium and Chromium – Nickel Stainless Steel Plate, Sheet, and Strip for Pressure Vessels and for General Applications Type 316 – Plate.
- 3.10 ASTM A240, Standard Specification for Chromium and Chromium – Nickel Stainless Steel Plate, Sheet, and Strip for Pressure Vessels and for General Applications Type 316L (If Welding is required).
- 3.11 SMUD Engineering Specification, SS4001 – Structural Concrete.
- 3.12 SMUD Engineering Specification, SS0801 – Polyvinyl Chloride Electrical Conduit.
- 3.13 ASTM F512, Standard Specification for Smooth – Wall Polyvinyl Chloride (PVC) Conduit and Fittings for Underground Installation.
- 3.14 NEMA TC 6 & 8 Polyvinyl Chloride (PVC) Plastic Utilities Duct for Underground Installation.
- 3.15 NEMA TC9, Fittings for Polyvinyl Chloride (PVC) Plastic Utilities Duct for Underground Installation
- 3.16 NEMA TCB2, NEMA Guidelines for the Selection and Installation of Underground Nonmetallic Raceways
- 3.17 NEMA 250 – 3R.
- 3.18 SMUD Ground Grid UVA1.6, UVA1.7, UVA1.8
- 3.19 NEMA GR-1 Grounding Rod Electrodes and Grounding Rod Electrode Couplings. See SMUD Specification UVA1.6, UVA1.7 and UVA1.8.
- 3.20 California Fire Code and National Fire Protection Association Standards.
- 3.21 IEEE 100CD Standards Dictionary: Glossary of Terms and Definitions
- 3.22 SMUD Commercial & Industrial Electric Service Requirements, T007, latest revision.
- 3.23 SMUD Fire Sprinkler System Specifications, latest revision.
- 3.24 ANSI/NEMA C57.12.28, Figure 1.
- 3.25 California Building Code
- 3.26 ***ASHTO - Standard Specifications for Highway Bridges***

4 Definitions

Definitions are defined in IEEE 100CD and the references in section 3 of this specification.

5 Vault Location

- 5.1 Transformer vaults shall be built on the customer's property at grade (street level) with at least one wall directly adjacent to the street or alley.
- 5.2 When a transformer vault at grade is not feasible, a transformer vault on the customer's property one-level below grade (sub-grade) can be considered pending SMUD Engineering approval.
- 5.3 If a transformer vault on the customer's property is not feasible, a transformer vault in the right-of-way (sidewalk) can be considered pending SMUD Engineering approval and approval from the appropriate jurisdiction having authority. Right-of-way feasibility is at the sole responsibility of the customer.
- 5.4 Any other location within the building requires SMUD Engineering approval.

6 Minimum Vault Dimensions

- 6.1 Vault dimensions are based on service size, service type (12 kV network or 21 kV) and location.

Table 1: In-Building Vault Location

TOTAL PANEL SIZE (Amps) ¹	V	SYSTEM	VAULT LOCATION	MIN. VAULT SIZE (LxWxH) (ft)	SWITCH SPACE (if necessary)
400 to 2,000	208	Network	In-Building	24 x 24 x 12	None
2,001 to 4,000	208	Network	In-Building	34 x 24 x 12	None
4,001 to 5,000	208	Network	In-Building	44 x 24 x 12	None
400 to 1,800	480	Network	In-Building	24 x 24 x 12	None
1,801 to 3,500	480	Network	In-Building	34 x 24 x 12	None
3,501 to 5,000	480	Network	In-Building	44 x 24 x 12	None
5,001 to 6,000	480	Network	In-Building	54 x 24 x 12	None
400 to 2,500	208	21 kV	In-Building	14 x 24 x 12	9 x 15
2,501 to 4,000	208	21 kV	In-Building	24 x 24 x 12	9 x 15
400 to 3,000	480	21 kV	In-Building	14 x 24 x 12	9 x 15
3,001 to 5,000	480	21 kV	In-Building	24 x 24 x 12	9 x 15

¹ Maximum allowable individual metering section is 4,000 Amps.

Table 2: Outside Building Vault Location

TOTAL PANEL SIZE (Amps) ²	V	SYSTEM	VAULT LOCATION	MIN. VAULT SIZE (LxWxH) (ft)	SWITCH SPACE (if necessary)	# OF EQUIP. HATCHES
400 to 2,000	208	Network	Outside	24 x 18 x 12	None	2
2,001 to 4,000	208	Network	Outside	34 x 18 x 12	None	3
4,001 to 5,000	208	Network	Outside	44 x 18 x 12	None	4
400 to 1,800	480	Network	Outside	24 x 18 x 12	None	2
1,801 to 3,500	480	Network	Outside	34 x 18 x 12	None	3
3,501 to 5,000	480	Network	Outside	44 x 18 x 12	None	4
5,001 to 6,000	480	Network	Outside	54 x 18 x 12	None	5
400 to 2,500	208	21 kV	Outside	14 x 18 x 12	9 x 15	1
2,501 to 4,000	208	21 kV	Outside	24 x 18 x 12	9 x 15	2
400 to 3,000	480	21 kV	Outside	14 x 18 x 12	9 x 15	1
3,001 to 5,000	480	21 kV	Outside	24 x 18 x 12	9 x 15	2

- 6.2 If a service has multiple panels, each panel will require the indicated space (21 kV).
- 6.3 Maximum allowable individual metering section is 4,000 Amps.
- 6.4 Please consult with SMUD Engineering for network service sizes in excess of 6,000 Amps or 21 kV services in excess of 5,000 Amps.
- 6.5 All 21 kV services may require additional switch space depending on the service size. Each switch requires a separate 9'x15' dedicated vault space (see SMUD Engineering Specification DS0608). Please consult with SMUD Engineering to determine if a switch is necessary.
- 6.6 Please see Drawings UVA1.1A and UVA1-1B for general illustrations and spacing requirements.

² Maximum allowable individual metering section is 4,000 Amps.

 SMUD ENG. SPEC. T001	REV. 10	CUSTOMER-BUILT VAULTS	page 5 of 35
---	------------	------------------------------	-----------------

6.7 Indicated space requirements are minimums. ***Variances to any of the dimensions or configurations requires SMUD Engineering approval.***

7 Vault Design

7.1 General Design Requirements

- 7.1.1 The vault's design shall meet all the requirements of this specification and any other applicable jurisdictional authority. The vault structure and all associated civil/structural items shall be designed by a currently licensed California Civil (or Structural) Engineer. The design loads given in this specification are minimum requirements, the Customer and Engineer of Record shall determine the highest load combination anticipated during the life of the structure.
- 7.1.2 The customer is required to submit all vault architectural, engineering drawings and calculations, and design plans for review in advance of construction. All drawings and calculations shall be reviewed, stamped and signed by a currently licensed California Civil (or Structural) Engineer. Other documents, not explicitly stated here, may be required by SMUD for review.
- 7.1.3 This specification is not intended to completely satisfy all responsibilities and obligations of the customer for SMUD electrical service.
- 7.1.4 The vault design shall be in accordance with CEC and NEC Article 450.
- 7.1.5 The customer shall furnish all material, resources and labor as required to engineer, design and construct the vault except as noted in Section 7.30 Materials Furnished by SMUD.
- 7.1.6 All materials utilized for construction shall be new. Reclaimed, recycled or reconstituted material shall not be accepted under any circumstances.
- 7.1.7 All concrete used for construction of the vault shall meet or exceed SMUD Specification SS4001 (Structural Concrete). Concrete of higher strength values shall be used when determined appropriate by the engineer of record having jurisdiction.
- 7.1.8 All vaults exposed to weather (e.g., Sidewalk Vaults) shall be considered subject to flooding/submergence and at a minimum be designed for an at grade water table. The vault design shall include a review of buoyancy to verify that the vault will not become buoyant under an at grade or flood water level condition. All equipment utilized shall be explicitly listed for submergence.

 SMUD ENG. SPEC. T001	REV. 10	CUSTOMER-BUILT VAULTS	page 6 of 35
---	------------	------------------------------	-----------------

7.1.9 All vaults that utilize a water-type fire suppression system shall be considered subject to flooding/submergence. All equipment utilized shall be explicitly listed for submergence.

7.1.10 It is the customer's sole responsibility to ensure that water does not enter the building or service entrance equipment from the vault space.

7.1.11 Should the customer request use of material/components that are of a non-pre-approved nature, the customer shall submit any and all information as determined necessary by SMUD staff for review. SMUD has the sole discretion to determine the appropriateness of the proposed substitute. The entire burden of proof is upon the customer to demonstrate compliance with the appropriate specifications. The customer shall allow a minimum of 25-business days for SMUD's review.

7.2 Equipment Access

7.2.1 At grade in-building vaults shall have at least one equipment access opening on the outside wall of the vault along the sidewalk or alley in a location that is accessible to SMUD vehicles, equipment and personnel.

7.2.1.1 All equipment access shall be sized to accommodate the installation, maintenance and removal of any installed electrical equipment.

7.2.1.2 Equipment access opening shall be at least 7'Wx8'H unless directed otherwise by SMUD Engineering.

7.2.1.3 All equipment access opening door(s) shall comply with Sections 7.4 Containment and 7.15 Fire Protection.

7.2.1.4 The door(s) shall be auto closing, have a panic bar and shall open outward from the vault.

7.2.1.5 The door shall be keyed to a SMUD "HA1" key.

7.2.1.6 A sign shall be placed on the door with the following: "DANGER, HIGH VOLTAGE, KEEP OUT. KEEP 10' CLEAR IN FRONT OF DOOR AT ALL TIMES."

7.2.1.7 This opening shall be at the opposite end of any personnel door (see Section 7.3 Personnel Access) to the vault. Please see UVA1-0A for additional information.

7.2.2 Below grade in-building vaults shall have at least one at grade equipment access opening.

7.2.2.1 Equipment access opening shall be located on the customer's property.

 SMUD ENG. SPEC. T001	REV. 10	CUSTOMER-BUILT VAULTS	page 7 of 35
---	------------	------------------------------	-----------------

- 7.2.2.2 If the equipment access opening cannot be placed on the customer's property, a location in the sidewalk area of the road right-of-way is acceptable upon SMUD Engineering approval. Right-of-way feasibility and approval is the sole responsibility of the customer.
- 7.2.2.3 The equipment access opening shall be a grated hatch or a removable solid-plug opening at least 10'x6' in size unless directed otherwise by SMUD Engineering. Please note that solid openings cannot be considered as part of any ventilation requirements for the vault (see Section 7.14 Ventilation).
- 7.2.2.4 The equipment access opening location shall not be directly over the transformer area. Please see UVA1-1A for additional information or consult with SMUD Engineering for acceptable locations.
- 7.2.2.5 The equipment access opening shall be designed for AASHTO H-20 full traffic plus 30% impact loading for any location within the road right-of-way or if the hatch location is accessible to any vehicular traffic, this includes all sidewalk locations.
- 7.2.2.6 If the equipment access opening is a grated hatch, the hatch shall have a built-in personnel entry hatch at least 3 feet long and the width of the equipment hatch (6 feet) with a fixed ladder (see Section 7.4 Ladders and UVA1.5).
 - 7.2.2.6.1 The personnel hatch shall be hinged, and torsion assisted with a maximum 35 lbs. of lifting force and open and lock 100 degrees from horizontal with 180 degree lay back capable.
 - 7.2.2.6.2 The hatch shall be securable with a pentahed bolts per ANSI/NEMA C57.12.28, Figure 1 and lockable with a recessed covered SMUD Padlock.
 - 7.2.2.6.3 The hatch shall be designed for AASHTO H-20 full traffic plus 30% impact loading for any location within the road right-of-way or if the hatch location is accessible to any vehicular traffic, this includes all sidewalk locations.
 - 7.2.2.6.4 The hatch shall be non-slip coated with SlipNOT (or SMUD-approved equivalent) and A.D.A. compliant and heel safe with a clear grate spacing not to exceed 5/16".
 - 7.2.2.6.5 All steel shall be hot-dipped galvanized or type-316 stainless steel at a minimum.

 SMUD ENG. SPEC. T001	REV. 10	CUSTOMER-BUILT VAULTS	page 8 of 35
---	------------	------------------------------	-----------------

- 7.2.2.7 If the equipment access opening is a removable solid-plug design, a 39" diameter steel round East Jordan (EJ) cover and frame shall be incorporated into the solid plug for personnel access. Part # 00341643A01 or SMUD approved equivalent. Set frame with 6# x 12" minimum radial rods.
- 7.2.3 Below grade sidewalk vaults shall have at grade equipment access openings as outlined in the Table found in Section 6.1.1 (# of Equip. Hatches).
- 7.2.3.1 The equipment access openings shall be a grated hatch design at least 10'x6' in size unless directed otherwise by SMUD Engineering.
- 7.2.3.2 All equipment access opening locations and configurations must be approved by SMUD Engineering. Please see UVA1-1B for typical equipment access opening locations and configurations.
- 7.2.3.3 The two-end equipment access opening hatches shall have a built-in personnel entry hatch at least 3 feet deep and the width of the equipment hatch (6 feet) with a fixed ladder (see Section 7.4 Ladders and UVA1.5).
- 7.2.3.4 All equipment access opening hatches shall be designed for AASHTO H-20 full traffic plus 30% impact loading for any location within the road right-of-way or if the hatch location is accessible to any vehicular traffic, this includes all sidewalk locations.
- 7.2.4 Grated equipment access openings shall not be located below or adjacent to building air intakes, windows that open and are operable, overhangs, canopies, doorways, entrance ways or ingress/egress routes.
- 7.2.5 Equipment access openings shall not be located in areas exposed to routine traffic (i.e., driveways, parking lot entrances, etc.).
- 7.2.6 All equipment access openings shall be securable with Pentahead bolts per ANSI/NEMA C57.12.28, figure 1.
- 7.2.7 All equipment access opening grates and solid plugs shall include recessed/flush lifting points to facilitate installation and removal of the grate or plug using 5/8" – 13NC eyebolts or lifting hardware.
- 7.2.8 All equipment access openings shall be A.D.A. compliant and heel safe with clear grate spacing not to exceed 5/16". All surfaces shall be non-slip coated with SlipNOT® or a SMUD approved equivalent.

 SMUD ENG. SPEC. T001	REV. 10	CUSTOMER-BUILT VAULTS	page 9 of 35
---	------------	------------------------------	-----------------

7.2.9 All equipment access grates, hatches, solid plugs and lift-outs shall be designed and engineered by a currently licensed California Civil (or Structural) Engineer. All drawings and calculations shall be submitted for SMUD review in accordance with Section 7.1 of this Specification.

7.2.10 All equipment access grates shall be lift-out, banded, welded, hot dipped galvanized steel or type-316 stainless steel.

7.3 Personnel Access

7.3.1 The vault shall have a minimum of two personnel access openings, located at the opposite ends of the vault.

7.3.2 At grade or below grade in-building vaults shall have the following requirements:

7.3.2.1 At least two doors are needed at the opposite ends of the vault.

7.3.2.2 Any personnel access door shall be at least 3' W x 6'8" H in size and shall be auto closing, have a panic bar and shall open outward from the vault.

7.3.2.3 An equipment access opening can fulfill part of this requirement provided it is placed at the opposite end of the vault to the personnel access door (see Sections 7.2.1 and 7.2.2 Equipment Access) and can be used as a personnel access point.

7.3.2.4 The door shall be keyed to a SMUD "HA1" key.

7.3.2.5 A sign shall be placed on the door with the following: "DANGER, HIGH VOLTAGE, KEEP OUT. KEEP 10' CLEAR IN FRONT OF DOOR AT ALL TIMES."

7.3.2.6 All personnel access doors shall comply with Section 7.5 Containment and Section 7.15 Fire Protection.

7.3.3 Please see Section 7.2.3 (Below Grade Sidewalk Vault Equipment Access) for personnel access requirements for below grade sidewalk vaults.

7.3.4 If a separate/dedicated personnel hatch is needed to fulfill the requirements of 7.3.1, this hatch must meet the following criteria:

7.3.4.1 Any dedicated personnel hatch must be at least 42x48 inches in dimensions, through the roof the vault and located at the opposite end of the vault to the other personnel entry hatch.

7.3.4.2 Meet all requirements listed in 7.2.2.6

 SMUD ENG. SPEC. T001	REV. 10	CUSTOMER-BUILT VAULTS	page 10 of 35
---	------------	------------------------------	---------------------

7.3.5 All personnel access points shall be accessible 24-hours a day, seven days a week by SMUD personnel. Ingress/egress, access to and from the vault shall not be blocked or impeded at any time.

7.4 **Ladders**

7.4.1 The customer shall supply, provide and install all required ladders.

7.4.2 The ladders shall meet CAL-OSHA General Industry Safety Order #3277.

7.4.3 The ladders shall be bolted rigidly in place and be removable.

7.4.4 The ladders shall be manufactured and installed in accordance with SMUD's drawing UVA1.5.

7.5 **Containment**

7.5.1 All conduits or other penetrations into the vault (especially for conduit floor penetrations) shall be designed to maintain the oil-containment requirements of the vault space if applicable. Please see 7.21.5 for additional information.

7.5.2 All equipment or personnel access doors shall have fluid-containment curbing installed.

7.5.2.1 The height of the curb shall be dependent on the oil volume requirements of any vault equipment but shall not be less than 6".

7.5.2.2 Additionally, when required by the Authority Having Jurisdiction, the curb height may be required to accommodate up to twenty minutes of water from the fire-suppression system (please contact the pertinent governing authority for additional information and requirements).

7.5.2.3 The curbing shall be removable by simple hand tools by a single person and still be watertight and withstand any pressures that could be generated as a result of any fire-suppression discharge.

7.5.2.4 All containment curbs shall be painted red.

7.5.3 All vaults housing equipment with a total oil volume capacity equal to or greater than 1,320 gallons of oil (equipment or containers storing less than 55 gallons of oil are not counted towards the total) shall have a secondary fluid containment installed in accordance to Title 40 Part 112 of the Code of Federal Regulations.

 SMUD ENG. SPEC. T001	REV. 10	CUSTOMER-BUILT VAULTS	page 11 of 35
---	------------	------------------------------	---------------------

7.5.4 The secondary containment must be able to accommodate the oil capacity of the largest oil-volume piece of equipment in the vault plus the larger of the following Freeboard:

7.5.4.1 When the vault is below grade with grated openings, precipitation from a 25-year, 24-hour storm.

7.5.4.2 Any fire-suppression discharge (if required by the Authority Having Jurisdiction).

7.6 Transformer Vault Accessibility

7.6.1 SMUD requires immediate and unimpeded personnel and equipment access to all vault entrances 24-hours a day without exception.

7.6.2 The customer shall maintain and facilitate a clear, unimpeded access for delivery, installation, replacement or maintenance of SMUD's equipment and materials.

7.6.3 Once SMUD has accepted the vault, sole access to the vault shall be controlled exclusively by SMUD.

7.6.4 Should the customer require access to the vault once it has been accepted by SMUD, the customer shall coordinate with SMUD for access and only be allowed to enter the vault when escorted by a trained and qualified SMUD electrical worker.

7.7 Walls

7.7.1 The walls of the vault shall be painted with not less than two coats of white paint. The paint shall be breathable, specifically designed for concrete, and meet any applicable codes or regulations for fire/fire resistance. All paint shall be applied in accordance with the manufacturer recommendations.

7.7.2 The vault walls shall be designed to withstand all pressures that could be generated by a fire suppression system discharge.

7.7.3 The vault walls shall be designed to withstand the controlling load combination considering applicable live load, dead load, seismic, all pressures that could be generated by a fire suppression discharge, all pressures that could be generated as a result of full internal (vault full of water) or external hydrostatic pressure, and AASHTO H-20 full traffic loading plus 30 percent impact.

 SMUD ENG. SPEC. T001	REV. 10	CUSTOMER-BUILT VAULTS	page 12 of 35
---	------------	------------------------------	---------------------

7.8 Ceiling

7.8.1 The vault depth shall be such that a minimum of 10' clearance from finished floor (F.F.) grade to the lowest obstruction is achieved. This includes, but is not limited to:

- Lighting
- HVAC
- Plumbing
- Fire Detection
- Span beams or other structural supports
- Bus Duct

The only exception to this requirement will be for cable tray and cable tap boxes. Height of cable tray above finished floor (F.F.) grade will be determined by Network Personnel, but generally will be installed at an elevation of 8'6" above F.F. grade. In general, a ceiling with a height greater than 15' above F.F. grade shall not be permitted unless explicitly approved in writing by SMUD Engineering.

7.8.2 The vault ceiling shall be designed to withstand the controlling load combination considering applicable live load, dead load, seismic, all pressures that could be generated by a fire suppression system discharge and AASHTO H-20 full traffic loading plus 30 percent impact.

7.8.3 The vault ceiling shall be painted with not less than two coats of white paint. The paint shall be breathable, specifically designed for concrete, and meet any applicable codes or regulations for fire/fire resistance. All paint shall be applied in accordance with the manufacturer recommendations.

7.9 Floor

7.9.1 The floor shall be constructed with a smooth fine-broom finish. Final finish shall provide a frictional coefficient that allows for foot traction, but not prevent the movement of equipment or create a trip hazard.

7.9.2 Slope of the floor shall not exceed 1% and shall allow flow to the drainage sumps.

7.9.3 Design and construct floor to support transformer equipment loads. SMUD to provide transformer equipment specifications, weight and base dimensions, to customer.

 SMUD ENG. SPEC. T001	REV. 10	CUSTOMER-BUILT VAULTS	page 13 of 35
---	------------	------------------------------	---------------------

7.10 Floor Drains

7.10.1 Floor drains, external to the vault, of any type are specifically prohibited from running in, through or traversing the vault.

7.11 Sump Pits

7.11.1 Sump pits are only required in subgrade vaults or as directed by SMUD Engineering.

7.11.2 A minimum of two sump pits are necessary for vaults required to have sump pits. Sumps shall be placed in locations adjacent to personnel access approximately 6" clear from any walls. The sump pits shall not be situated in any normal travel path.

7.11.3 The sump pits shall be 12"W x 24"L x 12"D. Each sump pit shall be covered with two – 12" removable grates. The grates can be either stainless steel or galvanized and shall be set flush with finished floor grade. Grates shall withstand 500lbs. point load with a minimum 3.0 safety factor.

7.11.4 The two sump pits shall be connected together with 1½" schedule 40, PVC water pipe. Gray PVC shall not be used.

7.11.5 A single 1½" schedule 40 PVC water pipe shall be utilized as a discharge line. The pipe shall start 3" above the sumps bottom.

7.11.6 The discharge line shall typically be routed to face of curb (F.O.C.).

7.11.6.1 Discharge lines shall not be routed through, across or traverse any building footprint.

7.11.7 A check valve shall be installed approximately 4' above finished floor grade and shall be capable of preventing any potential back-flow. All mounting hardware for the discharge line shall be type-316 stainless steel or better.

7.11.8 A switched and GFCI protected outlet shall be provided at a minimum of 6' above finished floor grade and located adjacent each personnel access and sump pit.

7.11.9 The customer shall supply all sump pumps. The customer shall utilize Little Giant Pump, Model 6E-CIA-SFS, Catalog Number: 506700 or a SMUD approved equivalent.

7.11.10 In general, a drain vent will not be required.

7.11.11 For all vault locations west of 7th Street that requires a sump pump, the sump pump shall have oil sensors (oil minders) such as the Stancor II Control System and SE-50 Sump Pump or SMUD approved equivalent.

 SMUD ENG. SPEC. T001	REV. 10	CUSTOMER-BUILT VAULTS	page 14 of 35
---	------------	------------------------------	---------------------

7.12 Vault Ground Grid

- 7.12.1 Refer to supplemental grounding information: UVA1.6, UVA1.7 and UVA 1.8.
- 7.12.2 All conductors utilized for the ground grid shall be 500kcmil copper conductor unless approved by SMUD Engineering.
- 7.12.3 The customer shall arrange for a ground impedance test with SMUD's Inspector. Testing shall be done within 5-days of installing the ufers and again when the vault has been completed. Total ground resistance shall not exceed 5-ohms upon the ufers being connected to the grid.
- 7.12.4 Should ground resistance of 5-ohms be exceeded, the customer shall consult with SMUD Engineering for resolution.
- 7.12.5 Please contact SMUD Engineering for any vault that is not built directly on native soil for site-specific grounding requirements.
- 7.12.6 Sidewalk vaults can use ground rods in lieu of the grounding requirements outlined in the supplemental section. Ground rods shall be 5/8" diameter x 8 ft in length Copper-clad and shall be placed in the four corners of the vault and every ten feet along the length and width of the vault.
- 7.12.7 All grounding installations shall be done in the presence of a SMUD inspector.
- 7.12.8 Any variances to the above-listed grounding requirements requires SMUD Engineering approval.

7.13 Water Proofing

- 7.13.1 The vault shall be designed to prevent any intrusion or migration of liquid through all walls, floors, ceiling(s) and joints. Furthermore, the vault shall be designed to contain any liquid for an indefinite amount of time. (Use XYPEX or SMUD approved equivalent to waterproof the exterior face and provide 2 strips of RAM-NECK Joint Sealant or SMUD approved equivalent at all joints)
- 7.13.2 Provide water proofing submittal or methodology to SMUD Designer for approval.

7.14 Ventilation

- 7.14.1 The ventilation/cooling system shall be provided to dispose of heat from the transformer total losses without creating a temperature rise that exceeds the transformer rating.

- 7.14.2 The customer is responsible for maintaining all aspects of the vault ventilation/cooling system to ensure proper and continued operation. Should, upon SMUD inspection, a component of the ventilation system is deemed not operable, the customer shall make repairs as necessary in a timely manner to ensure safe and continued operation. It is at SMUD's discretion to remove any transformer(s) from service should SMUD determine the transformer(s) are operating outside of its temperature rating.
- 7.14.3 Ventilation shall meet all building code requirements for occupied spaces and be sufficient for transformer cooling (CEC 450.9/450.45 etc.). The ventilation design shall be reviewed by SMUD Engineering.
- 7.14.4 All in-building or below grade in-building vaults shall have mechanical ventilation/cooling unless the vault has a grated equipment opening that meets the natural ventilation requirements set forth herein and is approved by SMUD Engineering.
- 7.14.5 All road right-of-way/sidewalk vaults shall use natural ventilation.
- 7.14.6 Any vault that requires mechanical ventilation shall not have a grated equipment opening.
- 7.14.7 Mechanical Ventilation
 - 7.14.7.1 A mechanical ventilation system shall be designed to maintain a maximum vault air temperature not to exceed 122° F with an assumed outside ambient air temperature of 104° F. The following contributed heat load for the transformers shall be utilized:

Table 3: Transformer Heat Load

Transformer Size (KVA)	Heat Load Per Transformer (In kW)
<= 1500	14.4
>1500	18.4

- 7.14.7.2 Transformer heat load shall be based on the infrastructure capability of the vault. Please consult with SMUD Engineering to determine the maximum transformer heat load requirements for the vault.
- 7.14.7.3 The mechanical ventilation system shall also take into account any other forms of heat load within the vault.
- 7.14.7.4 The mechanical ventilation system can be a recirculated cooling, positive or negative pressure fan-based system provided it meets all cooling and temperature requirements listed herein.

 SMUD ENG. SPEC. T001	REV. 10	CUSTOMER-BUILT VAULTS	page 16 of 35
---	------------	------------------------------	---------------------

- 7.14.7.5 Positive/negative pressure ventilation systems shall supply a minimum of 1.6 CFM per KVA of the infrastructure capability of the vault per b above.
- 7.14.7.6 Any fans for positive/negative pressure ventilation systems shall vent from or to outside air via direct-drive and shall be an Air Movement and Control Association (AMCA) Type A or B spark resistance with an explosion-proof motor.
- 7.14.7.7 The mechanical ventilation/recirculated cooling system shall be completely dedicated and shall not share any supply (source or exhaust) with building H.V.A.C.
- 7.14.7.8 The mechanical ventilation/recirculated cooling system shall be controlled via a thermostat(s) inside the vault located within three (3) feet of a personnel access door, at least five (5) feet above the F.F. grade.
- 7.14.7.9 The mechanical ventilation/recirculated cooling system, via thermostat(s) mentioned in e, shall activate at 90 F and shutoff at temperatures below 70 F.
- 7.14.7.10 A means of manually controlling the fans shall be provided inside the vault.
- 7.14.7.11 Intake and exhaust vents for any recirculating cooling system shall be located on the opposite ends of the vault.
- 7.14.7.12 Any external exhaust outlets shall not be located below or adjacent to building air intakes, windows that open and are operable, overhangs, canopies, doorways, entrance ways or ingress/egress routes. Please consult with the jurisdiction having authority for additional requirements.
- 7.14.7.13 All vent openings shall have a minimum opening space of 576 in².
- 7.14.7.14 Ventilation openings shall be covered with durable gratings and screens to prevent bird or rodent intrusion.
- 7.14.7.15 All ventilation openings in the vault shall have fire/smoke dampers that meet the minimum fire rating specified in the California Electrical Code and the California Building Code, including any local amendments and shall be motor operated. Only motor operators of a maintenance free type shall be accepted.
- 7.14.7.16 Any filters, screens, operators or other facilities that require maintenance shall be installed on the exterior of the vault and shall be serviced from the exterior of the vault.

 SMUD ENG. SPEC. T001	REV. 10	CUSTOMER-BUILT VAULTS	page 17 of 35
---	------------	------------------------------	---------------------

7.14.7.17 The ventilation system balance diagram showing designed inlet capacity, maximum inlet temperatures, duct sizes, ventilation placement and CFM shall be submitted to SMUD Engineering for review.

7.14.8 Natural Ventilation

7.14.8.1 Natural ventilation is only acceptable for vault locations with a grated equipment opening and is approved by SMUD Engineering.

7.14.8.2 The net area of ventilation opening, after reduction of the area occupied by screens, grates or louvers, shall not be less than three-square inches per transformer kVA.

7.14.8.3 Please consult with SMUD Engineering to determine the minimum KVA requirement as it pertains to the ventilation.

7.14.8.4 Please follow all other requirements for grated equipment openings as listed in Section 7.2 (Equipment Access).

7.15 Fire-Protection Requirements

7.15.1 There are two options for fire protection. The customer shall meet all requirements in either option pursuant to the jurisdiction having authority.

7.15.2 Option 1:

7.15.2.1 Meeting Vault requirements as outlined in CEC 450 Part 3.

7.15.2.2 3-hour fire resistance for walls, roofs and floors.

7.15.2.3 Solid doors with 3-hour fire resistance rating.

7.15.2.4 6" minimum removable door sill for fluid containment. See 7.5.4 for additional requirements.

7.15.2.5 Ventilation per CEC 450.9/450.45.

7.15.2.6 Drainage.

7.15.2.7 No SMUD required clearances to openings around vault door(s).

7.15.2.8 SMUD required clearances for installation, operation, and maintenance of units.

7.15.3 Option 2:

7.15.3.1 Fire-suppression system (see 7.15.4).

7.15.3.2 Installation of units with FM rated less-flammable fluids.

7.15.3.3 1-hour fire resistance rating for walls, roofs and floors.

7.15.3.4 Solid doors with 1-hour fire resistance rating.

 SMUD ENG. SPEC. T001	REV. 10	CUSTOMER-BUILT VAULTS	page 18 of 35
---	------------	------------------------------	---------------------

7.15.3.5 6" minimum removable door sill for fluid containment. See 7.5.4 for additional requirements.

7.15.3.6 Ventilation per CEC 450.9/450.45.

7.15.3.7 Drainage.

7.15.3.8 No SMUD required clearances to openings around vault door(s).

7.15.3.9 SMUD required clearances for installation, operation and maintenance of units.

7.15.4 Fire-Suppression System: In accordance with section 10.1.1, SMUD provides in these specifications (specifically section 7.15) its preferred methods for fire suppression. We provide no guidance on complying with applicable OSHA standards, Fire Department and other local authority specifications. We merely provide what we believe are the safest vault specifications as it relates to fire suppression. If a fire suppression system is installed due to requirements by the local authority having jurisdiction, the desire of the owner, or to meet 7.15.3 (Option 2), SMUD prefers the fire suppression system be a pre-action fire sprinkler designed in accordance with section 7.15.5, or a wet fire sprinkler system in lieu of a pre-action fire sprinkler system only if all criteria of section 7.15.6 are met. While SMUD believes these types of fire suppression are most effective in fighting transformer fires, alternatives as required by the local AHJ or regulations will be considered as an option. The local AHJ and SMUD shall approve the design of any fire-suppression system prior to the delivery of the transformer.

7.15.5 Pre-action fire sprinklers

7.15.5.1 Pre-action fire sprinklers shall be double interlock.

7.15.5.2 All associated detection shall be heat type detectors.

7.15.5.3 The sprinkler heads are to be intermediate temperature rated and standard response.

7.15.5.4 The sprinkler heads are to have a minimum k-factor of 8.0

7.15.5.5 The design density for the vault is to be a minimum of 0.30 gpm/sf.

7.15.5.6 Sprinkler heads are to be protected with listed guards.

7.15.5.7 Penetrations shall be sealed with an approved fire stopping system.

 SMUD ENG. SPEC. T001	REV. 10	CUSTOMER-BUILT VAULTS	page 19 of 35
---	------------	------------------------------	---------------------

7.15.6 Wet fire sprinklers

- 7.15.6.1 Sprinkler piping is not to run directly above the transformer and associated wiring and is to be located as far to the rear or the side of the vault as possible.
- 7.15.6.2 The sprinkler heads are to be intermediate temperature rated and standard response.
- 7.15.6.3 The sprinkler heads shall have a minimum k-factor of 8.0
- 7.15.6.4 The design density for the vault is to be a minimum of 0.30 gpm/sf.
- 7.15.6.5 Sprinkler heads are to be protected with listed guards.
- 7.15.6.6 A single control valve that controls the water supply to all sprinkler heads protecting vault shall be provided and located in the vault, to the rear, and easily visible and accessible to personnel without the use of a ladder or other tool.
- 7.15.6.7 A tamper switch connected to the building's fire alarm or sprinkler monitoring system shall be provided on the control valve.
- 7.15.6.8 Penetrations shall be sealed with an approved fire stopping system.

7.16 **Service Connections**

- 7.16.1 All in-building vaults can use busway or busway cable tap boxes to connect the vault to the customer's service entrance equipment. Service cables can be used for in-building vaults with SMUD Engineering approval. Please see drawings UVA1-1C, D and E for typical examples.
- 7.16.2 All road right-of-way/sidewalk vaults and/or vaults subject to flooding shall use service cables to connect the vault to the customer's service entrance equipment. Please see drawing UVA1-1E for a typical example.
- 7.16.3 All busway and busway cable tap box(es) shall meet or exceed NEMA 3R.
- 7.16.4 Orientation of the transformers and secondary connections will be dependent on the vault exit locations. The secondary side will always face or be closer to any vault exit. Any customer service connection will need to take this into consideration for service entrance location.
- 7.16.5 The location, height and disposition of any busway, busway cable tap box(es) or service entrance cables is vault/site specific and shall be designed and located in conjunction with SMUD Engineering and the Downtown Network Group.
- 7.16.6 Busway cable tap boxes shall be enclosed on 5-sides with the bottom to remain open and accessible.

 SMUD ENG. SPEC. T001	REV. 10	CUSTOMER-BUILT VAULTS	page 20 of 35
---	------------	------------------------------	---------------------

7.16.7 All sides of the busway cable tap box shall be removable.

7.16.8 Any jagged or sharp edges shall be protected via a shock absorbent bushing that will prevent injury.

7.16.9 Cable tap boxes shall accept a minimum of 10-runs of stranded 500kcmil copper conductor per phase and/or be sufficient to accommodate enough cables per the NEC to meet the service panel requirements.

7.16.10 Cable tap box(es) shall accept NEMA 2-hole compression type lugs (paddles). Set-screw connections shall not be accepted.

7.16.11 Busway penetrations shall comply with this specification and meet all applicable fire protection requirements.

7.17 **Service Conductors**

7.17.1 Service conductors, if used for the service connection, shall be stranded 500kcmil copper conductor.

7.17.2 SMUD's Designer will review the number of runs of conductor to be connected in the transformer vault.

7.17.3 Coordinate the excess length of conductor required inside the vault with SMUD's Inspector.

7.17.4 The service conductors shall be as close as practicable in length.

7.17.5 SMUD will provide the terminations inside the vault. Wire shall be "landed" via NEMA 2-Hole, long barrel type compression lugs (paddles).

7.18 **Cable Tray**

7.18.1 Cable tray, if applicable and/or required, shall be Cooper B-Line, aluminum, or SMUD-approved equivalent.

7.18.2 Cable tray shall be seismically braced for the Sacramento region. Bracing shall assume that the cable tray is loaded to 110% of capacity or as practical engineering guidelines call for; the most restrictive standard shall apply.

7.18.3 The customer shall supply all parts, resources and engineering involved with designing and installation of the cable tray system.

7.18.4 Cable tray height is typically 8.5 ft from the F.F grade. However, the specific heights to be determined on a case-by-case basis and dictated by the overall vault design.

7.19 **Structural Framing Channel (Unistrut)**

7.19.1 All structural framing channel shall be type-316 stainless steel, or better.

 SMUD ENG. SPEC. T001	REV. 10	CUSTOMER-BUILT VAULTS	page 21 of 35
---	------------	------------------------------	---------------------

- 7.19.2 All structural framing channel shall conform to Metal Framing Manufacturers Association Standard No. MFMA – 4, or better.
- 7.19.3 Concrete embedded channel (Unistrut) is the preferred construction method and shall be 1-3/8" x 1-5/8" 12 gauge, CooperBline "B32" type-316 stainless steel or better, or a SMUD approved equivalent. All channel shall be installed so that the lip of the channel is flush with the wall surface.
- 7.19.4 Surface mounted channel (Unistrut) shall be considered only if SMUD's Designer agrees that it is unfeasible to install embedded channel. Surface mounted channel shall be 1-3/8" x 1-5/8" 12 gauge, Cooper B-line "B32" type-316 stainless steel or better, or a SMUD approved equivalent.
- 7.19.5 Channel (Unistrut) on the ceiling will generally run perpendicular to the length of the vault. The first row at either end shall be placed 3' on center from the face of the interior vault wall and every 2' on center, thereafter. Channel shall be as evenly spaced as practicable to meet this requirement.
- 7.19.6 Wall mounted channel shall start at 4' above finished floor grade and be placed every 3' on center thereafter to the ceiling.
- 7.19.7 In general, all channel shall terminate 18" clear of any obstruction or wall.
- 7.19.8 All channel (embedded or surface mounted) shall be capable of supporting a minimum of 1000lbs/linear foot (1kp/lf.). Holding strength that only meets 1000lbs in a single location on the channel shall be considered a deficient design and shall not be accepted.

7.20 Pulling Irons

- 7.20.1 Pulling irons shall be type-316 stainless steel or better and embedded in concrete.
- 7.20.2 Each pulling iron shall have a minimum safe working load (SWL) rating of 11,000 lbs. applied in any direction. Each pulling iron shall have a minimum safety factor of not less than 3.0. Both the concrete area surrounding the pulling iron and the overall vault structure shall develop the minimum SWL of the pulling iron with a minimum safety factor of 3.0. All pulling irons shall be designed and engineered by a currently licensed California Civil (or Structural) Engineer. All drawings and calculations, with signature, shall be submitted to SMUD for review in accordance with Section 5.8 of this Specification.
- 7.20.3 The pulling iron shall have a minimum inside clearance of 3", when installed and blockout shall be designed to accommodate a 7/8" x 4 1/2" shackle.

 SMUD ENG. SPEC. T001	REV. 10	CUSTOMER-BUILT VAULTS	page 22 of 35
---	------------	------------------------------	---------------------

7.20.4 The customer shall reference drawing UVA1.4 for pulling iron locations. At a minimum, nine pulling irons shall be required and placed such that each iron is 18" on center above finished floor grade, 18" on center from the adjacent wall and 18" on center from the ceiling. The ninth pulling iron shall be located on the wall opposite the primary ductbank entrance and in line with centerline of the ductbank.

7.20.5 The vendor shall include stainless steel material test reports in the submittal. The material test reports shall include the actual yield and tensile of the stainless steel for all material used.

7.20.6 Inspection of Pulling Irons is required prior to forming and placing concrete.

7.21 Conduits (Primary and Secondary)

7.21.1 The customer shall furnish and install all conduits/ducts that are required pursuant to SMUD's Commitment package.

7.21.2 All conduits shall comply with SMUD Specification SS0801.

7.21.3 The minimum number and size of conduits required for SMUD's primary system and supervisory and control system will be determined by SMUD's Designer.

7.21.4 For all sidewalk vaults or vaults subject to flooding, the customer shall utilize stranded 500kcmil copper conductors for their service conductors and service connections. The size and number of conduits shall be pursuant to local agency requirements for this type of service conductor. The customer shall verify the proposed wire is compatible with SMUD connectors.

7.21.5 All conduits or other penetrations into the vault (especially for conduit floor penetrations) shall be designed to maintain the oil-containment requirements of the vault space and to prevent water intrusion into the vault from the connected subsurface manhole. The minimum height above finished floor grade shall be at least one (1) foot, encased in at least three (3) inches of concrete. Actual height will be dictated by oil containment and/or water intrusion prevention, whichever is higher or as required by SMUD Engineering.

7.21.6 All secondary conduits for service connections (if applicable) shall be sealed by the customer, after the conduits have been inspected and cable installed. Sealing shall be for the purposes of stopping water, smoke, and fire.

 SMUD ENG. SPEC. T001	REV. 10	CUSTOMER-BUILT VAULTS	page 23 of 35
---	------------	------------------------------	---------------------

7.21.7 The customer shall submit plans detailing the proposed route for secondary conduits to SMUD's Designer for review. Maximum angle PVC fittings in a single run shall not exceed 270 degrees.

7.21.8 Intermediate pullboxes in the secondary service run shall not be allowed.

7.21.9 All conduit(s) shall achieve a minimum of 3" of concrete encasement.

7.21.10 The customer shall consult with SMUD Engineering and the Downtown Network Group for locations in which the primary and secondary conduits shall penetrate the vault walls.

7.21.11 It shall be the responsibility of the customer to confirm with their civil engineer that the proposed conduit penetrations will not affect structural integrity of the vault. Differential movement shall be taken into account.

7.21.12 All Polyvinyl Chloride (PVC) conduits shall meet or exceed DB 120, gray in accordance with the latest revisions of ASTM F512 and NEMA TC6.

7.21.13 Any manufactured elbow shall meet or exceed Schedule 40, one-piece gray in color with an integral bell end.

7.21.14 All conduit fittings shall conform to ASTM F512 and NEMA TC9.

7.21.15 End bells shall be solid, one-piece, PVC and gray in color. End bells shall meet or exceed Schedule 40.

7.21.16 Plugs shall be utilized in every conduit. Conduit plugs shall be tapered and for the appropriate size of conduit.

7.22 Conduit System Installation (Ductbank)

7.22.1 All conduits to be conveyed to SMUD shall be installed in accordance with NEMA TCB2 and all applicable SMUD Specifications.

7.22.2 All conduits to be conveyed to SMUD shall be thoroughly cleaned and tested. The test shall consist of drawing an appropriately sized mandrel through each conduit. SMUD's Inspector will provide the mandrel. Mandrelling of the conduit shall only occur in the presence of SMUD's Inspector. A complete detailed report shall be generated by the customer detailing the following information:

7.22.2.1 The start time of each pull

7.22.2.2 The stop time of each pull

7.22.2.3 The size of mandrel that was pulled

7.22.2.4 The length of each pull

7.22.2.5 The position of each conduit where the test was started

 SMUD ENG. SPEC. T001	REV. 10	CUSTOMER-BUILT VAULTS	page 24 of 35
---	------------	------------------------------	---------------------

- 7.22.2.6 (i.e. conduit in the 2 x 1 position; identifies the conduit is in the second row, first column).
- 7.22.2.7 The position of each conduit where the test finished (i.e. conduit in the 3 x 2 position; identifies the conduit in the third row, second column).
- 7.22.2.8 The manhole, pullbox or vault number for the start of each test (SMUD's Inspector will provide this information).
- 7.22.2.9 The manhole, pullbox or vault number for the end of each test (SMUD's Inspector will provide this information).
- 7.22.2.10 The location of each conduit (i.e. west wall).
- 7.22.2.11 SMUD's Inspector will initial and date/time stamp each pull upon successful testing.
- 7.22.3 A steel brush shall not be used in the conduit.
- 7.22.4 Conduits which do not pass the mandrel test shall be repaired and retested. Repairs and retesting shall only occur in the presence of SMUD's Inspector.
- 7.22.5 All secondary conduits shall be installed and fire sealed pursuant to this specification and all applicable requirements.

7.23 Pull Tape (Pull Rope)

- 7.23.1 Inspection of Pull Tape (Pull Rope) is required prior to installing.
- 7.23.2 A flat pull rope shall be provided and installed by the customer in each conduit. The tape shall exceed the length of each conduit a minimum of 25' at each end and be a single, continuous run.
- 7.23.3 Knots in the pull rope are not acceptable.
- 7.23.4 The pull rope shall be tied to the end of the tapered conduit plug.
- 7.23.5 The pull rope shall be made of polyester, be lubricated and printed with footage markings or Kevlar and printed with footage markings.
- 7.23.6 The pull rope shall achieve a minimum tensile strength of 2500lbs.
- 7.23.7 Reclaimed rope shall not be accepted.

 SMUD ENG. SPEC. T001	REV. 10	CUSTOMER-BUILT VAULTS	page 25 of 35
---	------------	------------------------------	---------------------

7.24 Lighting

7.24.1 For all in-building vaults, the customer shall install and maintain lighting facilities within the vault. Lights will generally be placed 8' on center (O.C.) and be wall mounted at 10' above finished floor grade. Acceptable wall-mounted type units are Lithonia Lighting, Model (120V System) DMW-2-32W-120-GEB10IS or Model (277V System) DMW-2-32W-277-GEB10IS. Additional lighting may be required. It shall be the responsibility of the customer to provide a lighting diagram (Coefficient of utilization or Iso-foot-candle plot) that demonstrates lighting to all areas of the vault. Shadows in any portion of the vault are strictly prohibited. The lighting diagram shall account for all obstructions that will be in the vault (i.e., cable tray, HVAC, etc.).

7.24.2 If access doors are to be used, lighting shall be provided at each point of entry on the exterior of the vault.

7.25 Receptacles

7.25.1 A minimum of two receptacles shall be provided (In addition to dedicated outlets for any sump pump requirements). More may be required dependent upon the size of the vault. SMUD's Designer will confirm minimum number of outlets. Each outlet shall provide 120V single-phase domestic power.

If the customer will have back-up/emergency generation, the customer shall provide one outlet in the vault from the back-up generation that shall be labeled "Back-Up Vault Power" via engraved tag permanently affixed adjacent the outlet.

7.25.2 Outlets shall be GFCI protected, dedicated exclusively to vault power and clearly identified in the customer's panel as follows: "SMUD Vault Power".

7.25.3 All conduits, outlets, piping, wiring, apparatus and associated hardware shall be rated and UL Listed for use in a "Wet" environment.

7.26 Sound Insulation

7.26.1 Thermal or acoustical insulation of any type shall not be allowed in the vault.

7.27 Foreign Objects

7.27.1 Any object/facility not explicitly required by SMUD (i.e., piping, conduits, raceways, buss, vents, etc.) shall not be permitted to access, cross or traverse any portion of the vault under any circumstances.

 SMUD ENG. SPEC. T001	REV. 10	CUSTOMER-BUILT VAULTS	page 26 of 35
---	------------	------------------------------	---------------------

7.28 Identification

7.28.1 The customer shall permanently install a stainless steel, engraved placard adjacent a personnel access, on an interior wall with the following information:

- General Contractor of Record
- Sub-Contractor of Record for Construction of the Vault
- Electrical Contractor of Record
- Building Engineer Contact Information
- Year of Construction
- Design Floor Load
- Vault Number (To be supplied by SMUD's Inspector)

7.28.2 The lettering shall be engraved and a minimum of 3" high.

7.29 Material Furnished and installed by SMUD

7.29.1 All material in accordance with Rule and Regulation 16.

7.29.2 Ground grid conductors (excluding ufers) as part of the ground grid.

7.29.3 Secondary jumpers to cable tap boxes.

7.29.4 NEMA 2-Hole connectors, for terminating source side of conductor only.

7.29.5 Padlock(s) and doorway cylinder.

8 Inspection

8.1.1 SMUD will provide an Inspector who will be the line of communication between the Customer and SMUD during construction.

8.1.2 The hours of work for the Inspector are from 8:00 A.M. to 3:00 P.M., Monday through Friday. All work requiring the presence of the Inspector shall be scheduled during these hours. An advance notice of two (2) full working days shall be given to the Inspector for all work to be inspected, or as agreed to between the customer and the inspector.

8.1.3 It shall be the customer's responsibility to coordinate all inspection activities with SMUD's Inspector of record to ensure all required inspections are performed. SMUD's Designer will provide the name and phone number of the inspector of record once SMUD's Designer has reviewed and accepted the vault construction plans.

 SMUD ENG. SPEC. T001	REV. 10	CUSTOMER-BUILT VAULTS	page 27 of 35
---	------------	------------------------------	---------------------

- 8.1.4 The customer shall note all requests for inspection(s) in the daily log/as-built records for the vault. Performance of inspection will be noted and initialed by SMUD's Inspector of record upon successful completion. Unsuccessful performance of an inspection shall be noted in the daily log/as-built records for the vault.
- 8.1.5 All material and work shall be subject to inspection, examination, and testing by SMUD, at any time during manufacture, installation, or construction. The Customer shall provide and maintain proper facilities and safe access for such inspections or testing. The costs of all tests required under this inspection will be paid by the Customer.
- 8.1.6 SMUD reserves the right to reject defective materials and or workmanship that in its sole opinion does not comply with the reviewed plans. Furthermore, SMUD reserves the right to reject any material or workmanship that it determines to be insufficient or deficient for any reason.
- 8.1.7 Failure of the Customer to adhere to the inspection provisions outlined in this document may result in the Customer being required, at his/her expense, to remove, uncover, or otherwise enable inspection of such work by the Inspector.
- 8.1.8 Rejected work may result in delaying electric service until these inadequacies are corrected. The costs of correcting rejected work shall be paid by the Customer.
- 8.1.9 The customer shall submit to SMUD's Inspector, documentation from all agencies having jurisdiction detailing their inspection of the vault and stating their acceptance and/or approval. SMUD will not accept the vault as complete until these items in addition to all other applicable items have been addressed to SMUD's satisfaction.

8.2 **Limits of SMUD Review**

- 8.2.1 SMUD's review is normally limited to the area that is/ or will be occupied by SMUD's equipment and materials. However; when necessary to investigate compliance with SMUD's requirements, SMUD reserves the privilege to review any and all information necessary to ensure the safety of its staff. SMUD assumes no liability or responsibility with regards to local agency or higher jurisdictional compliance. The customer is responsible for reviewing all items with all applicable jurisdictions.

 SMUD ENG. SPEC. T001	REV. 10	CUSTOMER-BUILT VAULTS	page 28 of 35
---	------------	------------------------------	---------------------

8.3 As-built Documents

8.3.1 The customer shall keep daily as-built records for all work that pertains to SMUD. The customer shall confer with and receive authorization from SMUD's onsite Inspector to as-built field installations. SMUD's Inspector will sign and date/time stamp as-built records. The customer shall provide 2-hard copies and 1-CD (Electronic Copy) of all as-built records to SMUD's Inspector of record, prior to SMUD accepting the vault as complete.

9 Submittals

9.1.1 The Customer shall submit documentation showing compliance with this specification and shall include, but is not limited to:

9.1.1.1 Detailed vault site plan.

9.1.1.2 Any structural, electrical, mechanical and fire protection details and/or calculations of the vault or of any equipment inside the vault. All structural drawings and calculations must be reviewed, stamped and signed by a currently licensed Civil or Structural Engineer.

9.1.1.3 Material specifications for all material inside the vault or embedded in the vault concrete.

9.1.1.4 Other documents, not explicitly stated here, may be required by SMUD for review.

9.1.1.5 Transmittal letter.

9.1.2 All submittals shall be submitted prior to application for permit with the Authority Having Jurisdiction (AHJ). The purpose of this requirement is to allow the Customer to provide the AHJ with SMUD approved documentation.

All submittals shall include the following:

9.1.2.1 Three – Copies minimum of each item being submitted for review.

9.1.2.2 Transmittal letter.

9.1.2.3 Date of submittal (Or original date of submittal with date of resubmittal).

9.1.2.4 Date that completed review is being requested. Allow for a minimum of 15-business days for review of each item(s) submitted.

All submittals shall be directed to the SMUD Designer who is handling the job, either by email or by mail. Please contact the SMUD Designer for the latest mailing address.

 SMUD ENG. SPEC. T001	REV. 10	CUSTOMER-BUILT VAULTS	page 29 of 35
---	------------	------------------------------	---------------------

9.1.3 Additional information may be required by SMUD’s Designer or Engineer to determine compliance with this specification. In the case of engineering and design work, the plans shall be stamped in accordance with this specification.

9.1.4 All plans shall be signed and stamped by the engineer of record prior to submission to SMUD’s Designer for review.

9.1.5 Submittals marked “NOT APPROVED” shall be corrected and resubmitted for review.

9.2 Failure to Submit Required Information

9.2.1 Should the customer fail to submit the required information or execute work in advance of review by SMUD’s Designer or other SMUD Department having jurisdictional approval, the customer, at their expense shall rectify any and all deficiencies as a result of performing this work at their expense.

9.3 Resubmittal of Information

9.3.1 Resubmittal shall include the following:

9.3.1.1 Three – Copies minimum, of each item being submitted for review.

9.3.1.2 Transmittal letter.

9.3.1.3 Original of preceding submittal (Previous plans with back-check comments).

9.3.1.4 Date of submittal also include date of original submittal on transmittal sheet.

9.3.1.5 Date that completed review is being requested. Allow for a minimum of 15-business days for review of each item submitted.

9.4 Scheduling

9.4.1 The customer shall provide a construction schedule to SMUD’s Scheduling Department. The schedule shall provide adequate time for SMUD’s Engineering and Design review of the proposed transformer vault. A minimum of five weeks is typically required for a complete review.

9.4.2 The schedule shall include the following:

9.4.2.1 Date the vault construction is to begin.

 SMUD ENG. SPEC. T001	REV. 10	CUSTOMER-BUILT VAULTS	page 30 of 35
---	------------	------------------------------	---------------------

9.4.2.2 The date construction of the vault will be complete. The customer shall allow time in the construction schedule for field inspections as required by SMUD's Inspector, local agency inspector, special inspector or any inspector/inspecting authority have jurisdiction. Note that SMUD does not consider the transformer vault construction complete until SMUD controls exclusive access to the vault. SMUD will not begin construction until all criteria of this specification have been satisfied.

9.4.2.3 The date that permanent service is requested.

9.4.2.4 The customer shall submit to SMUD's Scheduling staff, any changes impacting the construction schedule.

10 Standards and Codes

10.1.1 This specification does not relieve nor indemnify the customer from complying with all applicable codes, ordinances, or other industry standards or practices.

10.1.2 Where there is conflict between this specification and codes, ordinances, industry standard practices, local agency requirements, etc., the customer shall notify SMUD in writing for resolution. In most cases, the most restrictive standard shall apply.

10.1.3 Any issues that arise as a result of conflict with this specification and any applicable codes shall be resolved in advance of constructing the transformer vault.

10.1.4 Any engineering, design or construction that will deviate from SMUD's Engineering Specification T001 or the plans explicitly reviewed by SMUD's staff shall be validated in writing by SMUD's Designer or Inspector. Should the developer fail to receive written authorization from SMUD, and the performed work is determined to be deficient, the customer, at their expense shall correct the deficiencies.

11 Permits, Licenses and Bonds

11.1.1 The customer, at their expense shall obtain, secure and execute all permits, licenses and bonds necessary for the execution of all work related to acquiring service from SMUD.

11.1.2 The customer, at their expense shall obtain, secure and execute all necessary permits/licenses to design and engineer all required portions of the transformer vault. All work shall be signed and stamped by a currently licensed engineer within the State of California within the appropriate discipline. All stamped and signed drawings and calculations shall be submitted to SMUD for review.

 SMUD ENG. SPEC. T001	REV. 10	CUSTOMER-BUILT VAULTS	page 31 of 35
---	------------	------------------------------	---------------------

12 Appendix A: List of Material Suppliers

The table below lists material suppliers with whom SMUD is familiar. It is not intended to be an exhaustive list of all possible suppliers in the area. There may be additional vendors that can provide the material required by this specification.

Anti-Slip

SlipNOT Metal Safety Flooring

800-SlipNOT (800-754-7668) or 313-923-0400

www.slipnot.com

Cable Tray

Cooper B-Line

800-851-7415

www.cooperblineline.com

Series 2, 3 & 4 Aluminum Cable Tray, 12" Rung spacing.

Consult SMUD Designer for width requirements.

Channel

Cooper B-Line

800-851-7415

Cooper B-line "B32" type-304 12-gauge stainless steel

www.cooperblineline.com

<http://www.cooperblineline.com/product/PDFLibrary/StrutSystems/index.htm>

Equipment Hatch

Madrug Iron Works, Inc. 209-832-7003

www.madrugaironworks.com

<http://www.madrugaironworks.com/SMUD%206X12%20G&C.pdf>

6'-0" x 10'-0" 3-Piece, Drag-Off Grates, Frame and Cover

Minimum live load design requirement: AASHTO full traffic plus 30% impact applied at any location on the surface.

 SMUD ENG. SPEC. T001	REV. 10	CUSTOMER-BUILT VAULTS	page 32 of 35
---	------------	------------------------------	---------------------

Equipment/Personnel Hatch

Madruga Iron Works, Inc.

209-832-7003

www.madrugaironworks.com

<http://www.madrugaironworks.com/SMUD%206X12%20G&C.pdf>

6'-0" x 10'-0" 2-Piece, D/O Grates and Hinged Alum Cover, Frm & Cvr –

Minimum live load design requirement: AASHTO full traffic plus 30% impact applied at any location on the surface.

Ground-Grid components

FCI

800-346-4172

www.fciconnect.com

Burndy Type YGF Ground Plate, size for 500kcmil CU wire

Burndy Type YGHC-C rebar connector, sized for 500kcmil CU wire

Burndy Type YGL-C cross connector, sized for 500kcmil CU wire

Lights

Lithonia Lighting

770-922-9000

www.lithonia.com

Model (277V System) DMW-2-32W-277-GEB10IS

Model (120V System) DMW-2-32W-120-GEB10IS

 SMUD ENG. SPEC. T001	REV. 10	CUSTOMER-BUILT VAULTS	page 33 of 35
---	------------	------------------------------	---------------------

Pull Rope

Arnco. No. DLWP 25S-3000

Neptco No. WP 2500P

Pacific Strapping NO FMT-P2500

Fibertek NO WP2500

Advance Fiber Tech (AFT) WPP2500PL

Wellington Slicktape N303M10-9083

Redback PW2500

Milliken MT2500-3000

Safety Post

Bilco Specialty Access Products

203-934-6363

www.bilco.com

<http://www.bilco.com/foundations/store/shopdetail.asp?product=1LU%2D1>

Model LU-2, Galvanized Steel

Required for each ladder.

Sump Pump

Little Giant Pump Company

888-956-0000

www.littlegiant.com or www.lgpc.com

Model: 6E-CIA-SFS (or SMUD approved equivalent)

Catalog Number: 506700

For all vaults located west of 7th Street:

Stancor Pumps

860-391-5794

<http://stancorpumps.com/>

Stancor II Control System and SE-50 Sump Pump (or SMUD approved equivalent)

 SMUD ENG. SPEC. T001	REV. 10	CUSTOMER-BUILT VAULTS	page 34 of 35
---	------------	------------------------------	---------------------

13 Appendix B: Design and Construction Drawings

The customer and/or their representatives or contractors shall adhere to the design and construction drawings listed in the table below, unless otherwise specified in writing by a SMUD inspector or designer. The Customer shall review all drawings. Any questions or comments shall be brought to Sacramento Municipal Utility District's (SMUD) attention for clarification or resolution.

Design and Construction Drawings

Drawing Title	Drawing Identification Code	Page Number
MINIMUM SPACE REQUIREMENTS FOR AN IN-BUILDING VAULT	UVA1.1A	B-1
MINIMUM SPACE REQUIREMENTS FOR AN SIDEWALK VAULT	UVA1.1B	B-2
SERVICE CONNECTION EXAMPLE: CUSTOMER BUS (TYPICAL) FOR AN AT-GRADE/IN-BUILDING VAULT	UVA1.1C	B-3
SERVICE CONNECTION EXAMPLE: BUS CABLE TAP BOX (TYPICAL) FOR A BELOW-GRADE/IN-BUILDING VAULT	UVA1.1D	B-4
SERVICE CONNECTION EXAMPLE: CUSTOMER WIRE (TYPICAL) FOR A SIDEWALK VAULT	UVA1.1E	B-5
STRUCTURAL CHANNEL LOCATIONS IN TRANSFORMER VAULT & TRANSFORMER VAULT CONDUIT ENTRANCE	UVA1.3	B-6
PULLING IRON LOCATIONS FOR TRANSFORMER VAULT	UVA1.4	B-7
REQUIREMENTS FOR FIXED LADDERS IN VAULTS AND MANHOLES	UVA1.5	B-8
GROUND PLATE PLACEMENT AND SPACING DETAILS	UVA1.6	B-9 to 11

 SMUD ENG. SPEC. T001	REV. 10	CUSTOMER-BUILT VAULTS	page 35 of 35
---	------------	------------------------------	---------------------

Drawing Title	Drawing Identification Code	Page Number
REBAR CONNECTION DETAILS	UVA1.7	B-12 to 15
BELOW GRADE GROUNDING ELECTRODE CONFIGURATIONS	UVA1.8	B-16 to 20
DETAIL TYPICAL CONDUIT TERMINATION	U12P3X2	B-21

21KV (IN BUILDING VAULT)			
PANEL SIZE	VOLTAGE	MIN. VAULT SIZE (LxWxH)	SWITCH SPACE (IF NECESSARY) ^D
400 TO 2,500 AMPS	208	14' x 24' x 12'	15' x 9'
2,501 TO 4,000 AMPS	208	24' x 24' x 12'	15' x 9'
400 TO 3,000 AMPS	480	14' x 24' x 12'	15' x 9'
3,001 TO 5,000 AMPS	480	24' x 24' x 12'	15' x 9'

NETWORK (IN BUILDING VAULT)		
PANEL SIZE	VOLTAGE	MIN. VAULT SIZE (LxWxH)
400 TO 2,000 AMPS	208	24' x 24' x 12'
2,001 TO 4,000 AMPS	208	34' x 24' x 12'
4,001 TO 5,000 AMPS	208	44' x 24' x 12'
400 TO 1,800 AMPS	480	24' x 24' x 12'
1,801 TO 3,000 AMPS	480	34' x 24' x 12'
3,001 TO 5,000 AMPS	480	44' x 24' x 12'
5,001 TO 6,000 AMPS	480	54' x 24' x 12'

^APLEASE SEE NOTE D FOR ADDITIONAL SWITCH SPACE REQUIREMENTS

NOTES:

- A. SHOWN CONFIGURATIONS ARE TYPICAL. ACTUAL CONFIGURATIONS CAN VARY. PLEASE CONSULT WITH SMUD ENGINEERING FOR VAULT LAYOUT AND BUILDING LOCATION APPROVAL.
- B. AT LEAST TWO DOORS/ENTRANCES NEEDED ON OPPOSITE ENDS OF THE VAULT. AN EQUIPMENT ACCESS CAN BE CONSIDERED AS PART OF THIS REQUIREMENT IF IT CAN BE USED AS A PERSONNEL ENTRY.
- C. IT IS THE CUSTOMER'S SOLE RESPONSIBILITY TO ENSURE THAT WATER DOES NOT ENTER THE BUILDING OR SERVICE ENTRANCE EQUIPMENT FROM THE VAULT SPACE.
- D. ALL 21 KV SERVICES MAY REQUIRE ADDITIONAL SWITCH SPACE DEPENDING ON THE SERVICE SIZE. EACH SWITCH REQUIRES A SEPARATE 9'x15' DEDICATED VAULT SPACE (SEE SMUD ENGINEERING SPECIFICATION DS0608).
- E. ALL IN-BUILDING VAULTS SHALL BE FULLY ACCESSIBLE BY SMUD AT ALL TIMES.

**IN-BUILDING VAULT (1ST FLOOR)
PLAN VIEW (TYPICAL)^B**

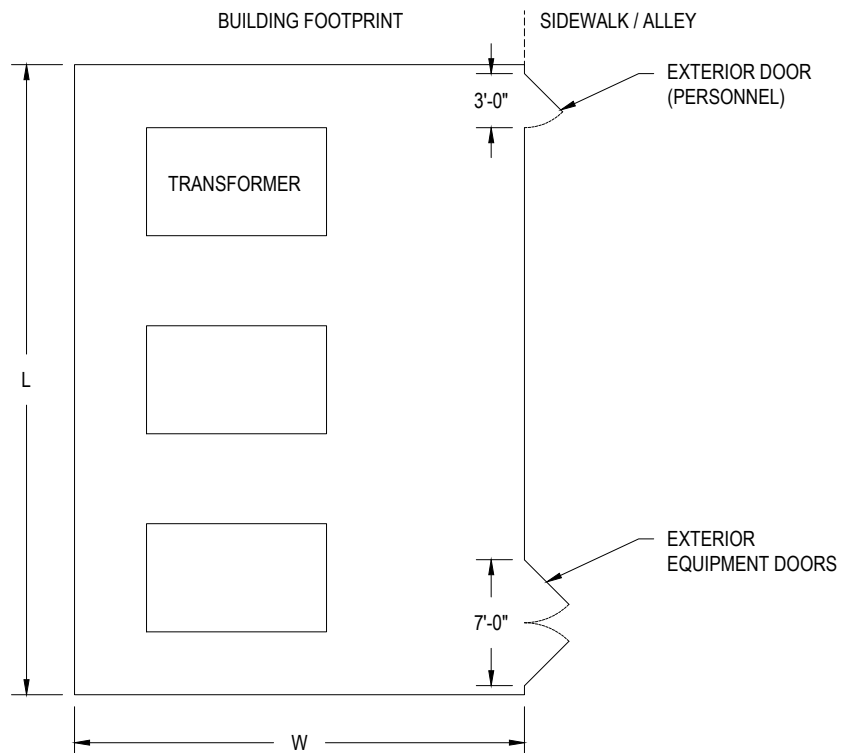

^BPLEASE SEE SMUD T013 FOR ALTERNATIVE ENCLOSURE/ALCOVE SPACE REQUIREMENTS FOR 21 KV 1ST/ FLOOR IN-BUILDING TRANSFORMER SPACE.

**PARTIAL IN-BUILDING VAULT (BASEMENT)
PLAN VIEW (TYPICAL)^c**

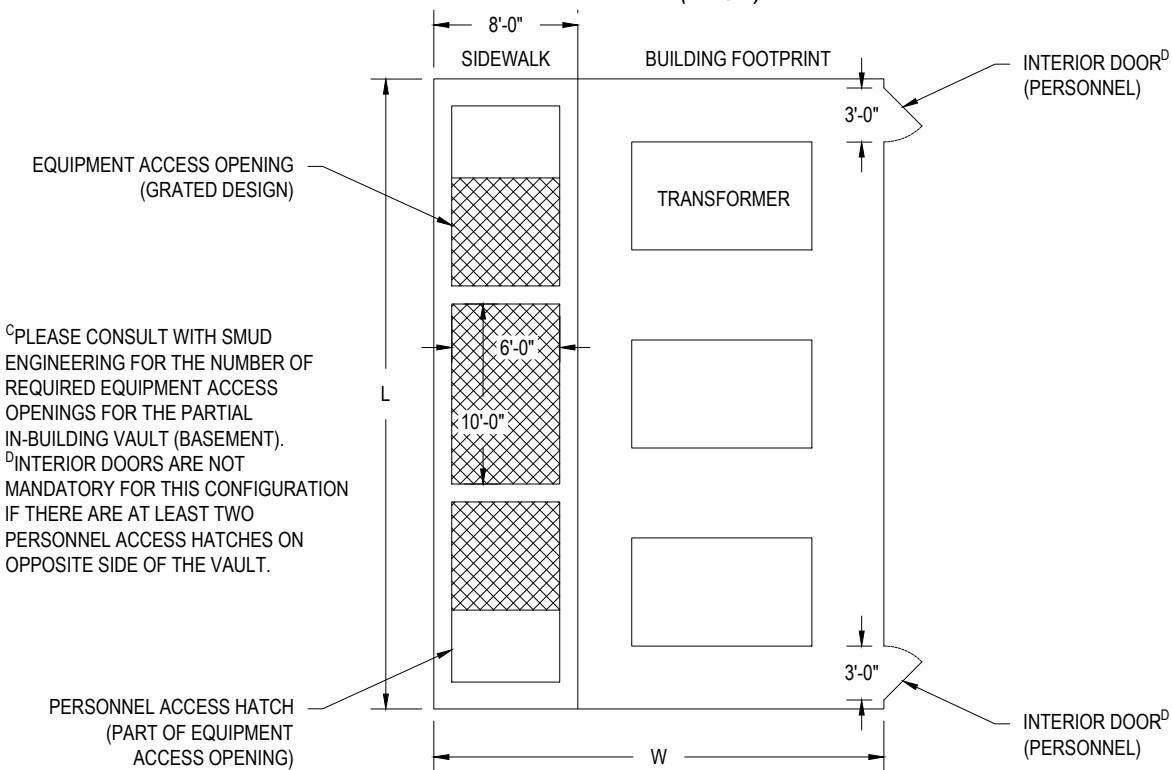

^cPLEASE CONSULT WITH SMUD ENGINEERING FOR THE NUMBER OF REQUIRED EQUIPMENT ACCESS OPENINGS FOR THE PARTIAL IN-BUILDING VAULT (BASEMENT).
^dINTERIOR DOORS ARE NOT MANDATORY FOR THIS CONFIGURATION IF THERE ARE AT LEAST TWO PERSONNEL ACCESS HATCHES ON OPPOSITE SIDE OF THE VAULT.

**IN-BUILDING VAULT (BASEMENT)
PLAN VIEW (TYPICAL)**

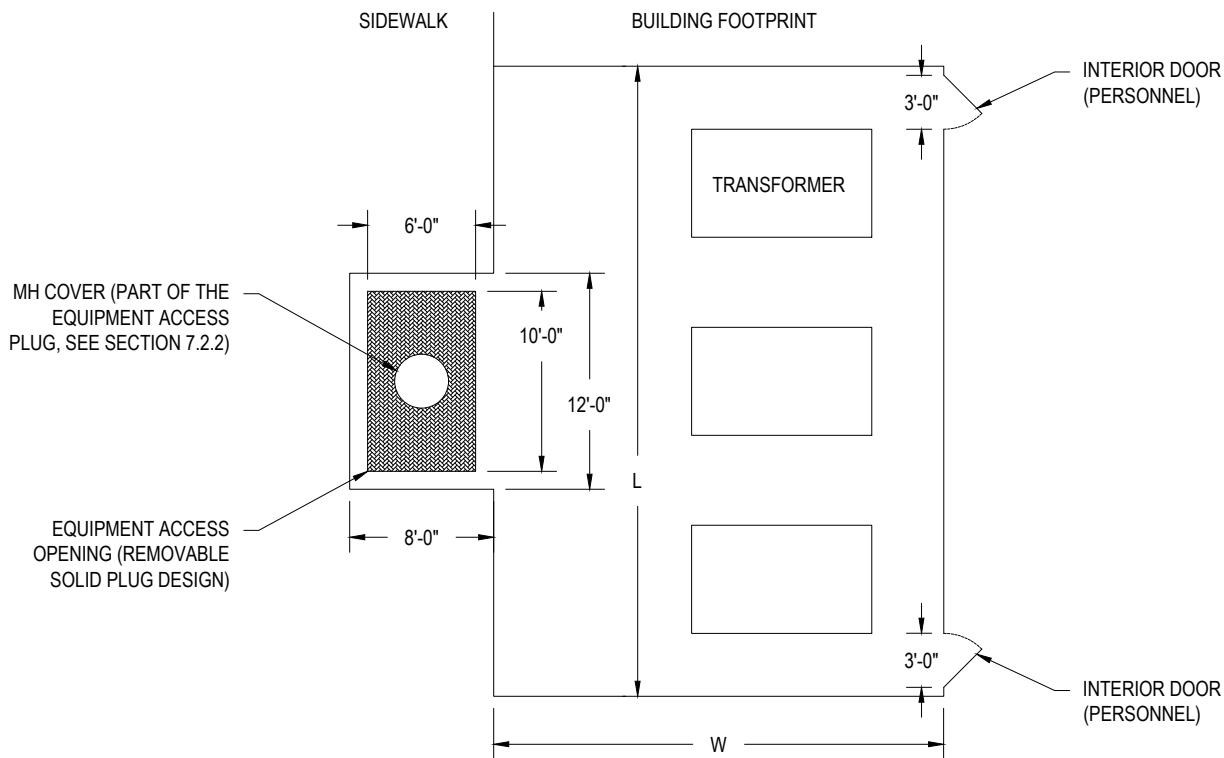

21KV (SIDEWALK VAULT)				
PANEL SIZE	VOLTAGE	MIN. VAULT SIZE (LxWxH)	SWITCH SPACE (IF NECESSARY) ^F	# OF EQUIPMENT HATCHES
400 TO 2,500 AMPS	208	14' x 18' x 12'	15' x 9'	1
2,501 TO 4,000 AMPS	208	24' x 18' x 12'	15' x 9'	2
400 TO 3,000 AMPS	480	14' x 18' x 12'	15' x 9'	1
3,001 TO 5,000 AMPS	480	24' x 18' x 12'	15' x 9'	2

NETWORK (SIDEWALK VAULT)			
PANEL SIZE	VOLTAGE	MIN. VAULT SIZE (LxWxH)	# OF EQUIPMENT HATCHES
400 TO 2,000 AMPS	208	24' x 18' x 12'	2
2,001 TO 4,000 AMPS	208	34' x 18' x 12'	3
4,001 TO 5,000 AMPS	208	44' x 18' x 12'	4
400 TO 1,800 AMPS	480	24' x 18' x 12'	2
1,801 TO 3,000 AMPS	480	34' x 18' x 12'	3
3,001 TO 5,000 AMPS	480	44' x 18' x 12'	4
5,001 TO 6,000 AMPS	480	54' x 18' x 12'	5

^APLEASE SEE NOTE F FOR ADDITIONAL SWITCH SPACE REQUIREMENTS

NOTES:

- A. SIDEWALK VAULT FEASIBILITY IS AT THE SOLE RESPONSIBILITY OF THE CUSTOMER.
- B. ANY SIDEWALK LOCATION MUST BE APPROVED BY SMUD ENGINEERING PRIOR TO INSTALLATION.
- C. TWO PERSONNEL ACCESS HATCHES NEEDED ON OPPOSITE ENDS OF THE VAULT.
- D. AN EQUIPMENT ACCESS OPENING CAN SERVE AS A DOOR/ENTRANCE (SEE 7.2).
- E. IT IS THE CUSTOMER'S RESPONSIBILITY TO ENSURE THAT WATER DOES NOT ENTER THE BUILDING OR SERVICE ENTRANCE EQUIPMENT FROM THE VAULT SPACE.
- F. ALL 21 KV SERVICES MAY REQUIRE ADDITIONAL SWITCH SPACE DEPENDING ON THE SERVICE SIZE. EACH SWITCH REQUIRES A SEPARATE 9'x15' DEDICATED VAULTED SPACE (SEE SMUD ENGINEERING SPECIFICATION DS0608).
- G. VAULT SHALL BE FULLY ACCESSIBLE BY SMUD AT ALL TIMES.
- H. ANY PERSONNEL HATCH THAT IS PART OF THE EQUIPMENT HATCH MUST BE AT LEAST 3' DEEP AND THE WIDTH OF THE EQUIPMENT HATCH (6').

**SIDEWALK VAULT
PLAN VIEW (TYPICAL)**

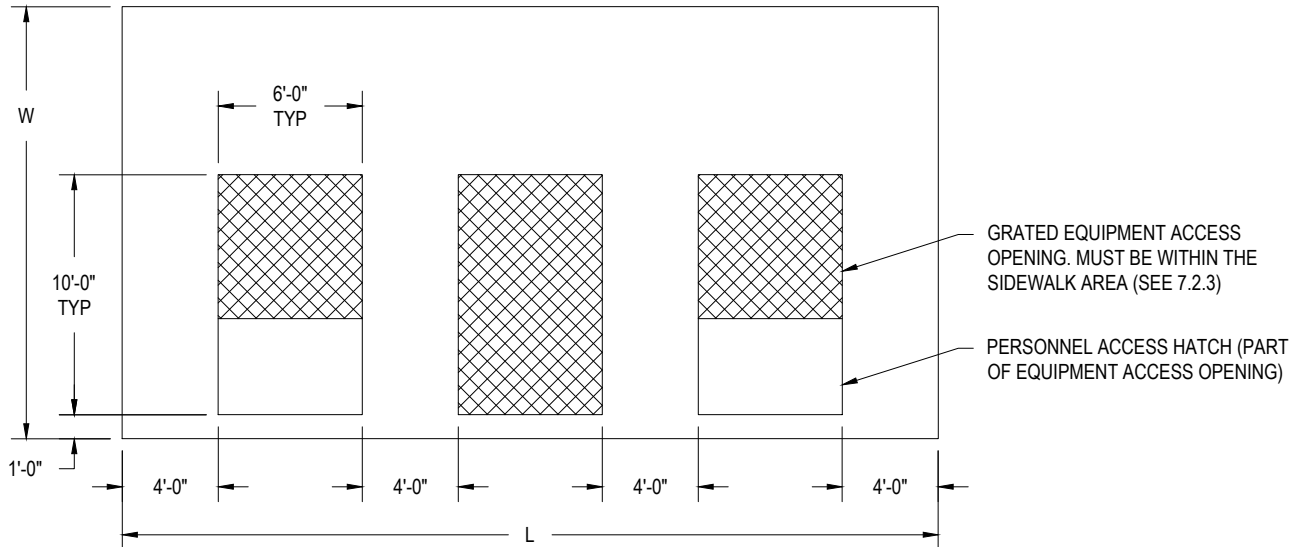

**SIDEWALK VAULT
PLAN VIEW (TYPICAL)**

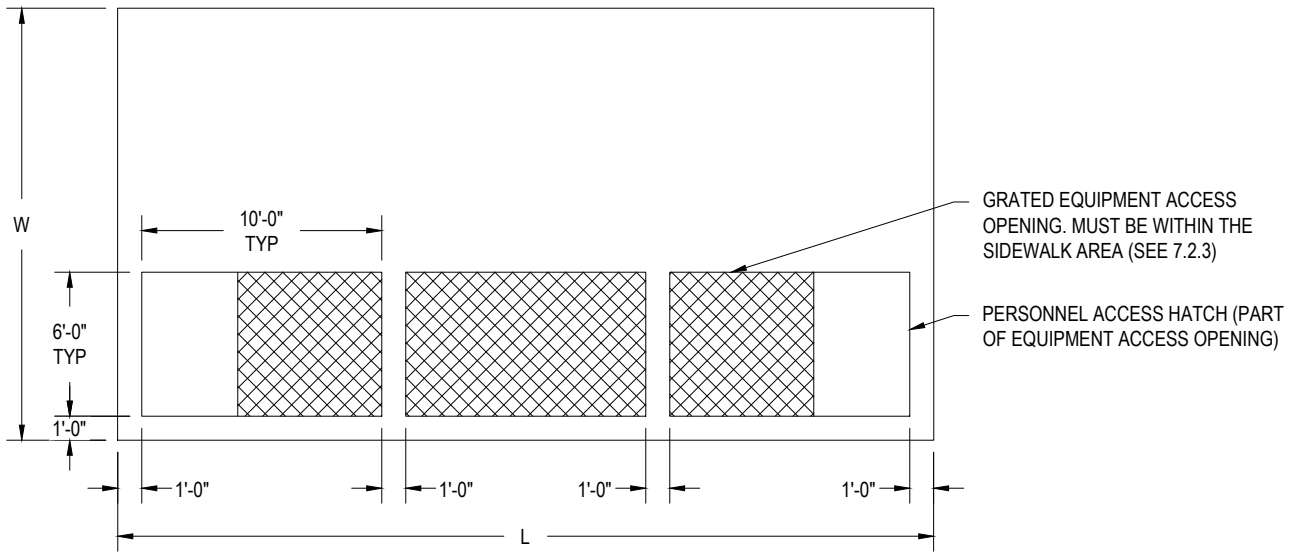

**SIDEWALK VAULT
PROFILE VIEW (TYPICAL)**

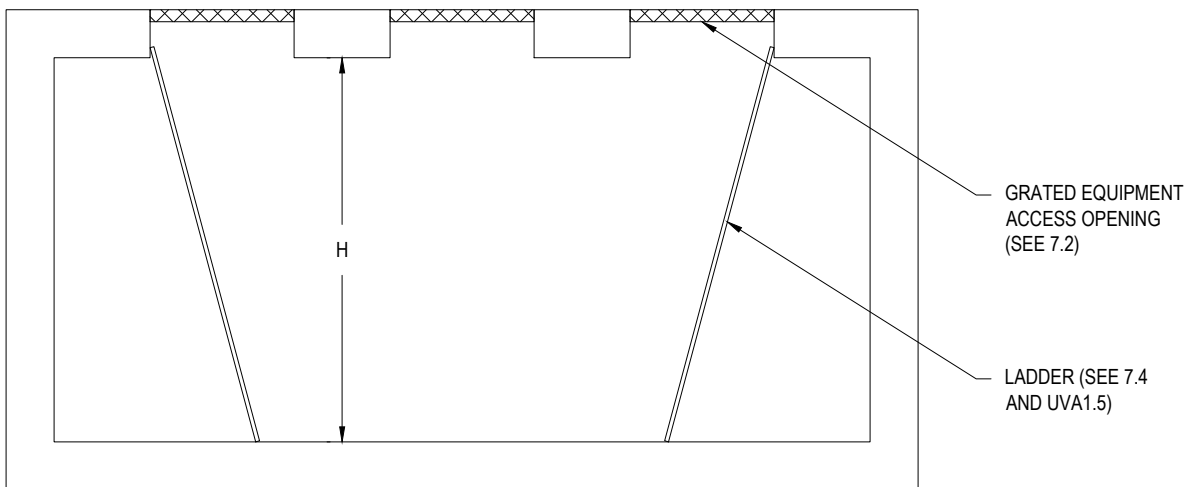

NOTES:

- A. SHOWN CONFIGURATIONS ARE TYPICAL. ACTUAL CONFIGURATIONS CAN VARY.

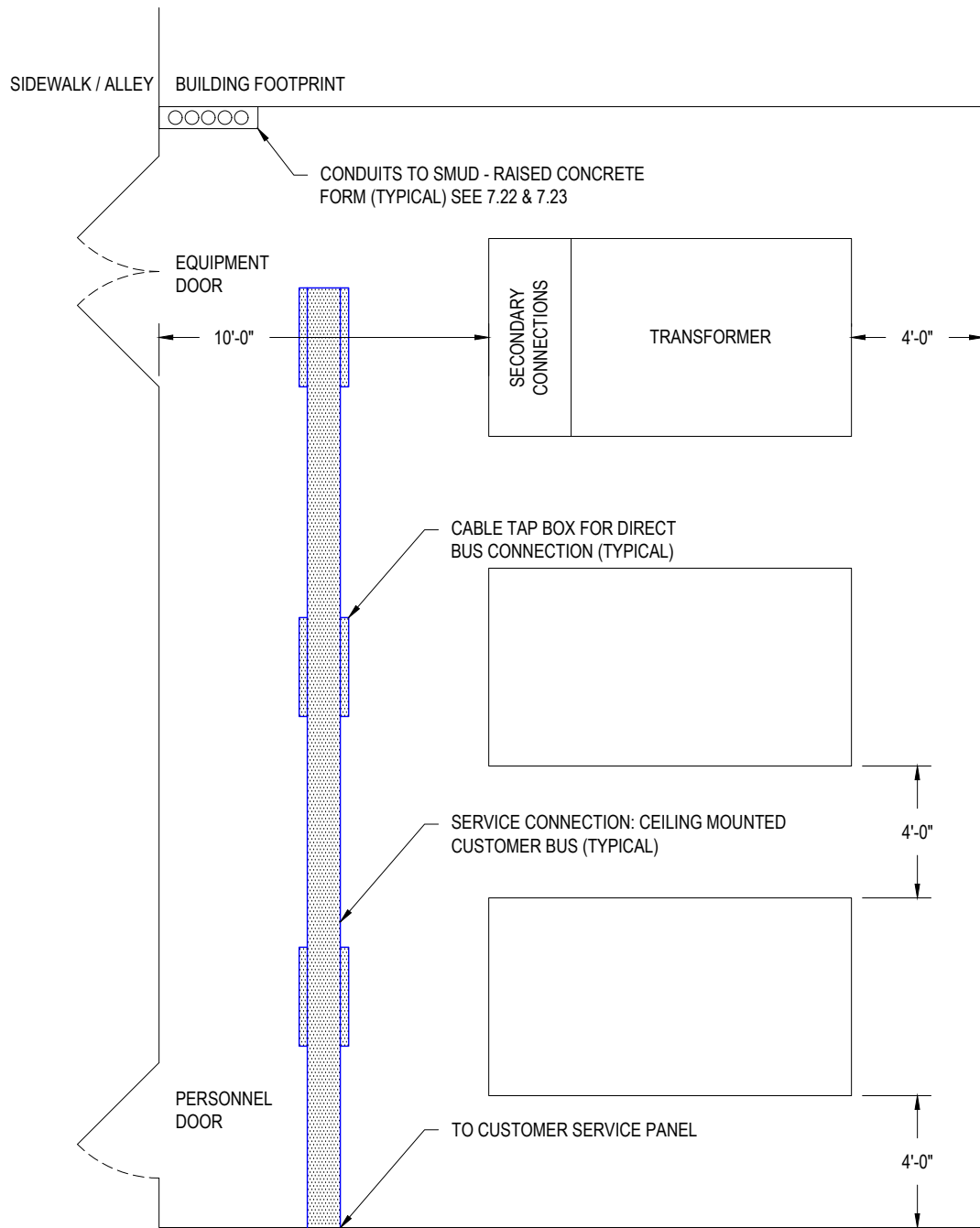

ESR: T001

ESR PG. NO.: B-3

REV. DATE: MARCH 2020
REV. NO.: 0

**SERVICE CONNECTION: CUSTOMER BUS (TYPICAL)
(AT-GRADE, IN-BUILDING VAULT)**

STANDARD NO.:
UVA1.1C

NOTES:

- A. SHOWN CONFIGURATIONS ARE TYPICAL. ACTUAL CONFIGURATIONS CAN VARY.

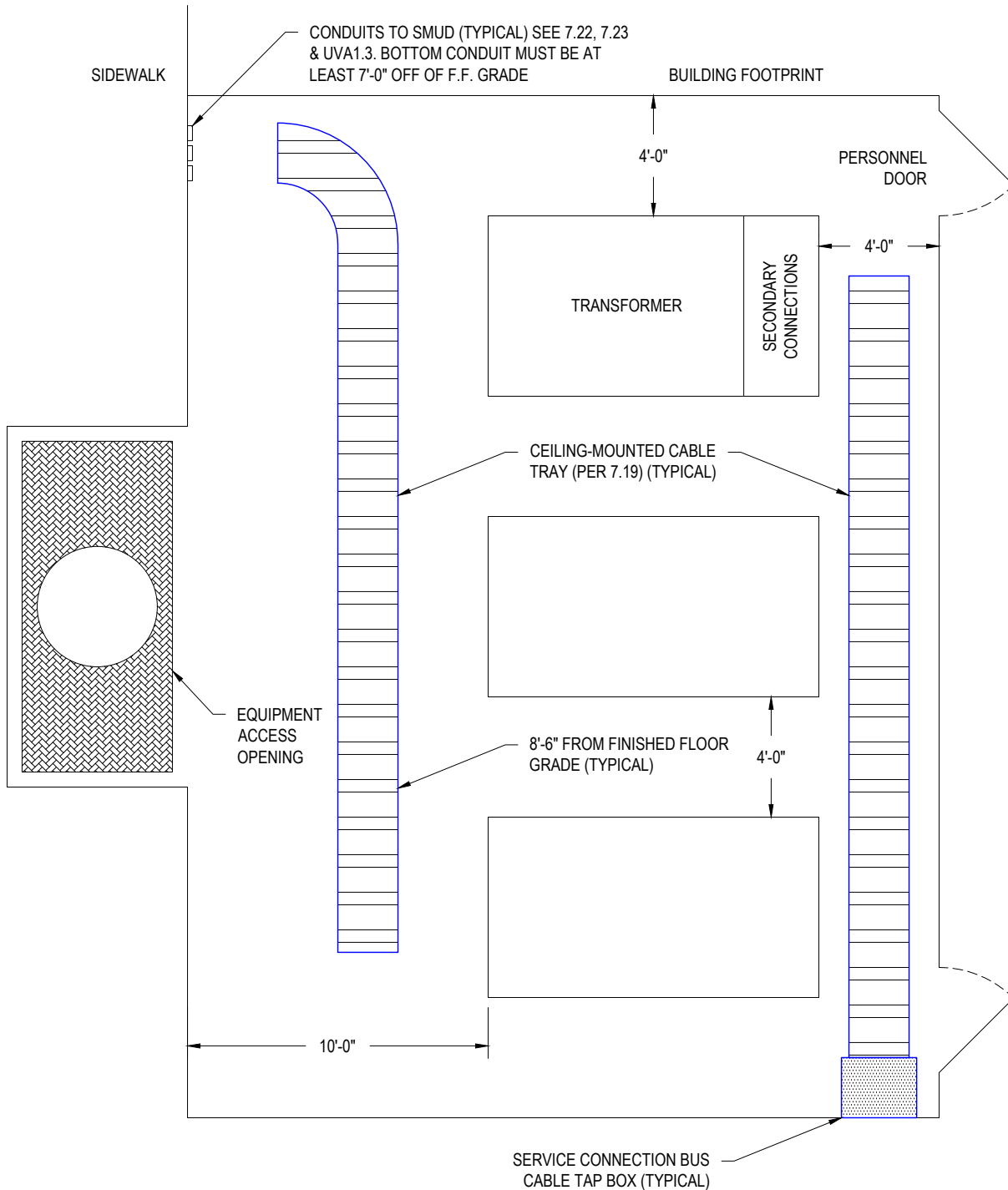

NOTES:

- A. SHOWN CONFIGURATIONS ARE TYPICAL. ACTUAL CONFIGURATIONS CAN VARY.

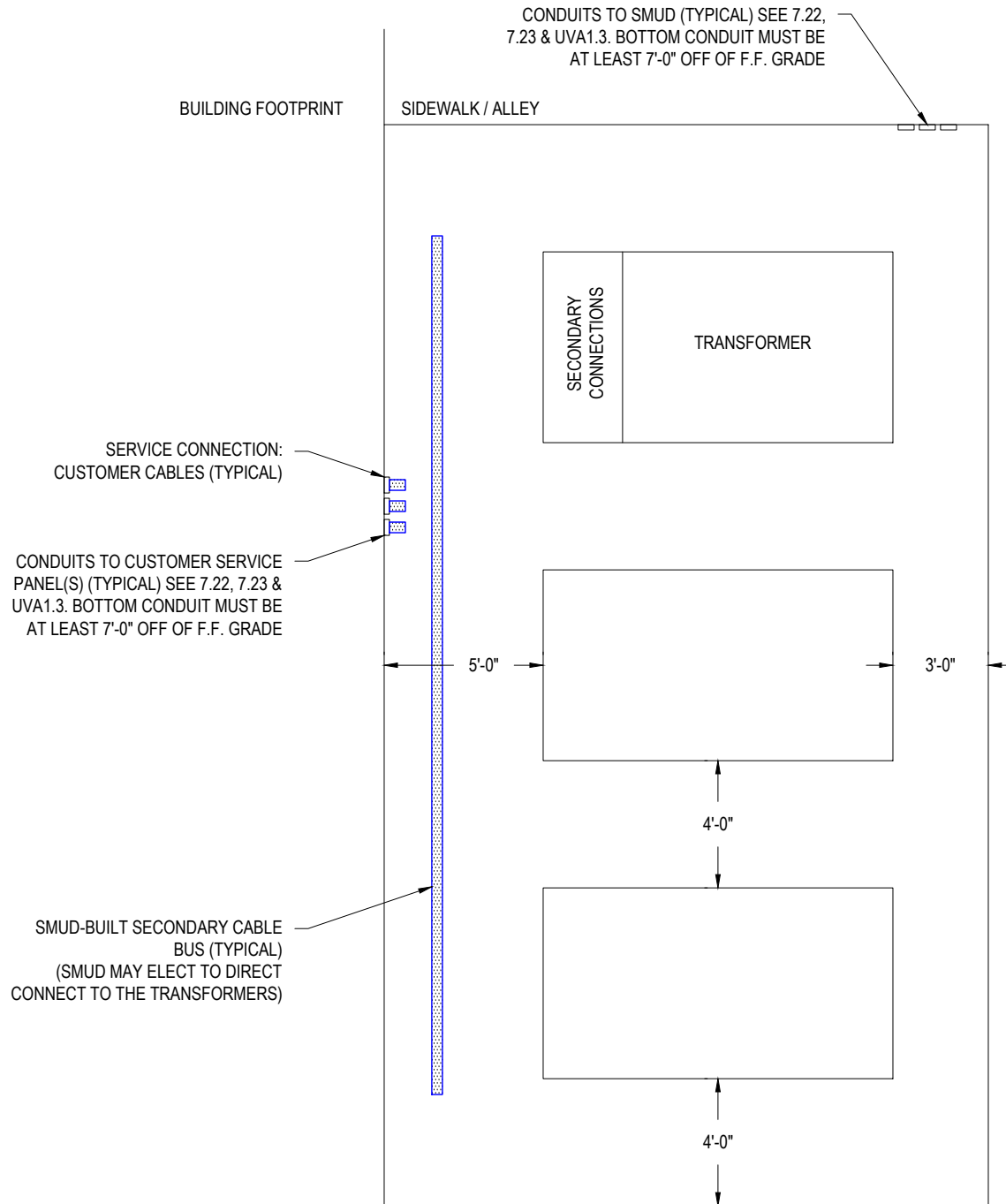

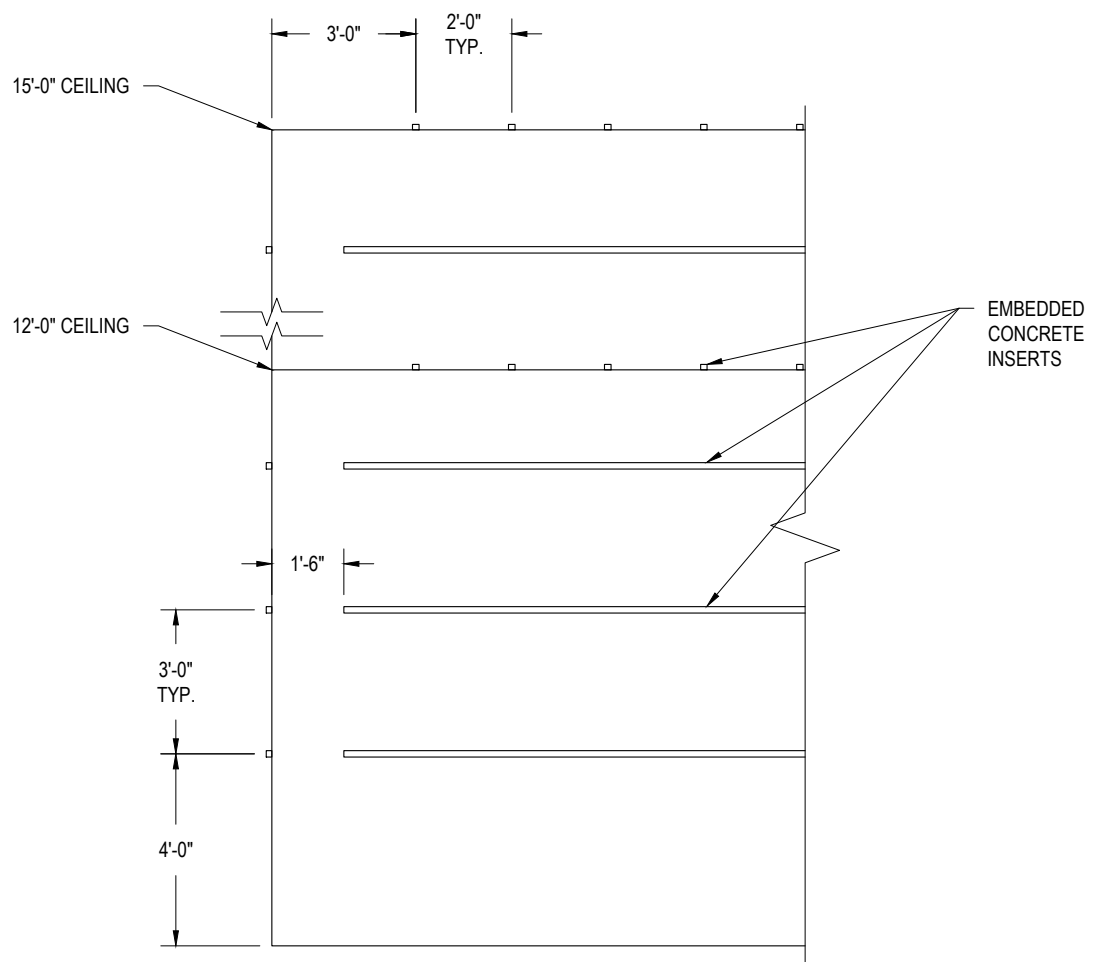
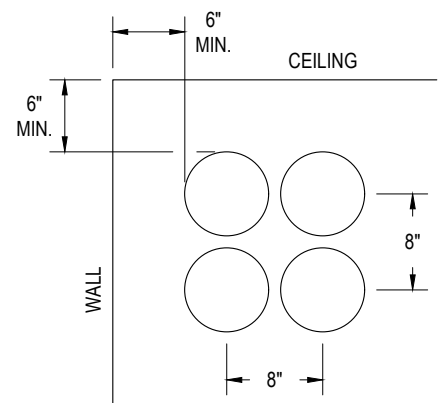
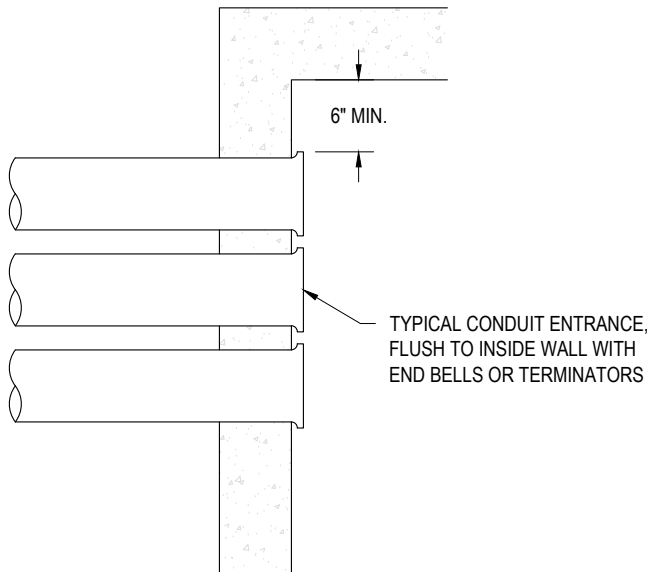

ESR: T001

ESR PG. NO.: B-6

REV. DATE: OCTOBER 2020
REV. NO.: 1

STRUCTURAL CHANNEL LOCATION IN
TRANSFORMER VAULT &
TRANSFORMER VAULT CONDUIT ENTRANCE

STANDARD NO.:
UVA1.3
PAGE 1 OF 1

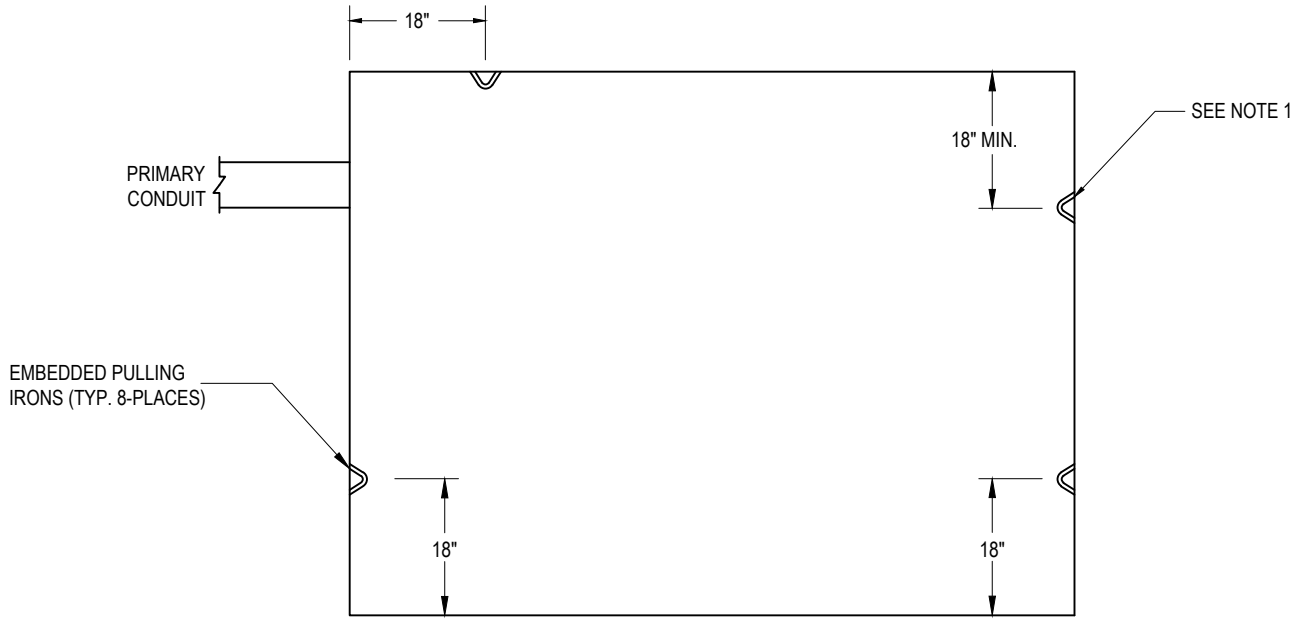

PLAN

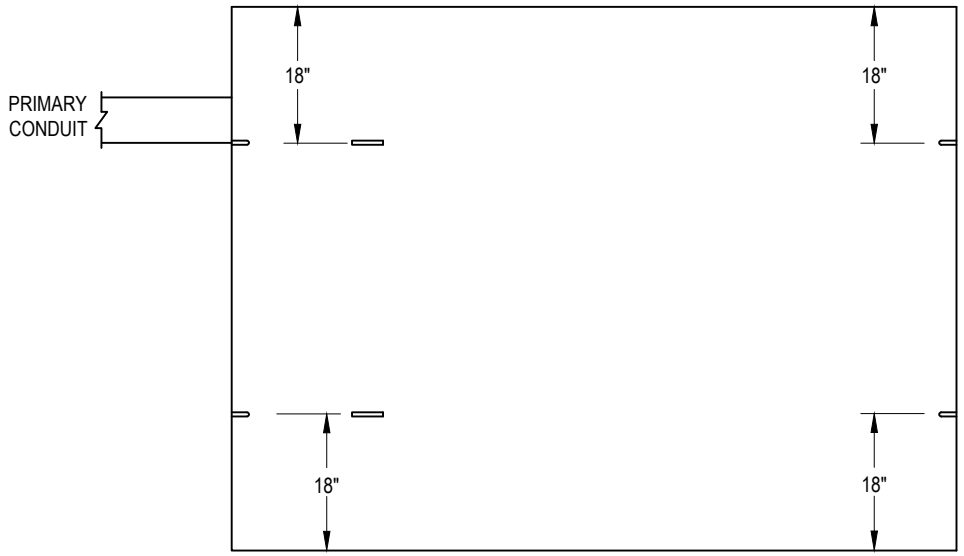

PROFILE

NOTE:

1. THIS PULLING IRON SHALL BE IN LINE WITH AND LEVEL WITH THE CONDUIT ENTRANCE, BUT NOT CLOSER THAN 18" TO THE CEILING.



ESR: T001

PG #: B-7

REV. DATE: JAN 2016
REV. NO.: 1

**PULLING IRON LOCATIONS
FOR TRANSFORMER VAULT**

STANDARD NUMBER:

UVA1.4

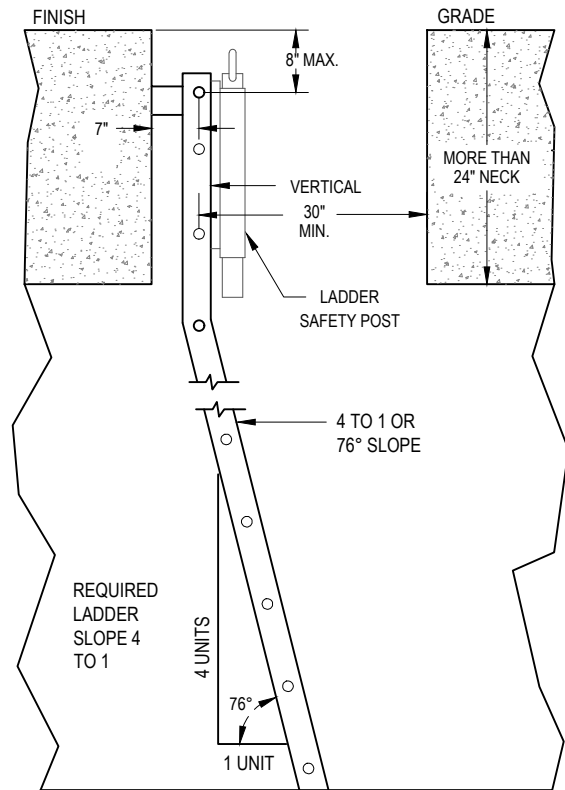
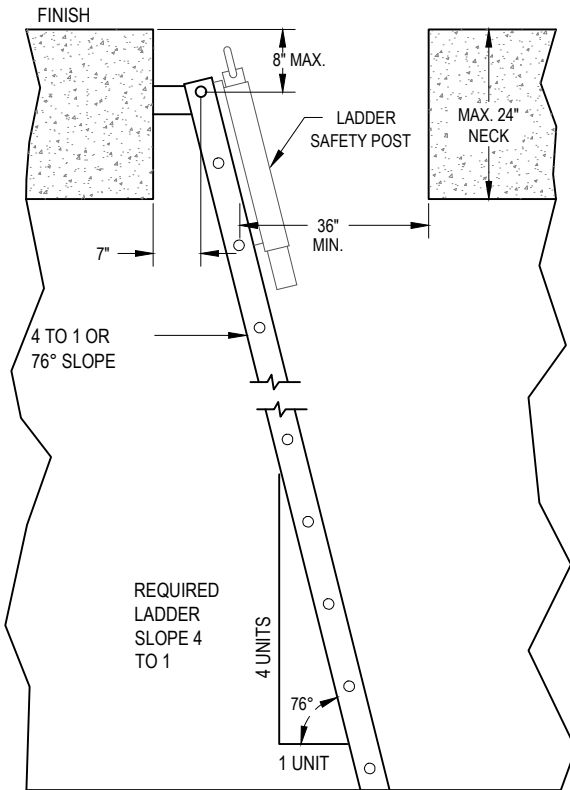

THE PERPENDICULAR DISTANCE FROM THE CENTER LINE OF THE RUNGS TO THE NEAREST PERMANENT OBJECT ON THE CLIMBING SIDE SHALL BE NOT LESS THAN 30" FOR LADDERS WITH A PITCH OF 90 DEGREES AND 36" FOR LADDERS WITH A PITCH OF 76 DEGREES.

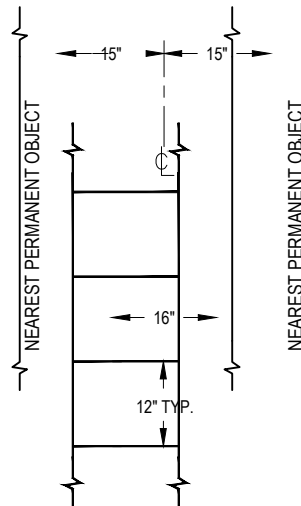

LADDER SPACING

NOTES:

- LADDER DESIGN AND FABRICATION SHALL BE IN ACCORDANCE WITH THE LATEST EDITION OF ANSI A14.3.
- FABRICATOR SHALL PROVIDE STAMPED AND SIGNED CALCULATIONS BY A CALIFORNIA LICENSED PROFESSIONAL CIVIL OR STRUCTURAL ENGINEER FOR THE LADDER DESIGN AND THE LADDER ANCHORAGE DESIGN.
- LADDER DESIGN AND ANCHORAGE SHALL BE DESIGNED FOR THE WORST CASE LOADING CONDITION, INCLUDING THE CONDITION OF LOADING APPLIED TO THE EXTENDED LADDER UP SAFETY POST.
- LADDER AND ALL COMPONENTS SHALL BE ASTM A36 STEEL MINIMUM AND SHALL BE HOT DIP GALVANIZED ACCORDING TO ASTM A123 AND A153.
- RUNGS SHALL BE 3/4" DIAMETER MINIMUM WITH AN ANTI SLIP SURFACE OF SLIP NOT GRADE 2 MEDIUM OR SMUD APPROVED EQUIVALENT.
- RAILS SHALL BE 3/8" X 3" MINIMUM.
- LADDERS SHALL BE ATTACHED AT TOP AND BOTTOM TO THE VAULT OR MANHOLE AND SHALL BE REMOVABLE.
- LADDER UP SAFETY POST SHALL BE BILCO OR SMUD APPROVED EQUIVALENT WITH 42" EXTENSION.
- THE LADDER BOTTOM RUNG SHALL BE 14" MAXIMUM ABOVE THE VAULT OR MANHOLE FLOOR.

NUMBERED NOTES:

- ① INSTALL BURNDY TYPE YGF GROUND PLATES (OR SMUD APPROVED EQUIVALENT) SIZED FOR 500 KCMIL CONDUCTOR 3" FROM THE WALL AND SPACED AS EVENLY AS POSSIBLE AROUND THE PERIMETER OF THE VAULT, NOT EXCEEDING 10' DISTANCES BETWEEN EACH GROUND PLATE. ENSURE A GROUND PLATE IS INSTALLED IN EACH CORNER OF THE VAULT. ALL GROUND PLATES ARE TO BE CONNECTED TO THE REBAR IN THE FLOOR. REFER TO UVA1.7 FOR IN CONCRETE INSTALLATION AND CONNECTION DETAILS, INCLUDING REBAR CONNECTION REQUIREMENTS.
- ② IN ADDITION TO THE REQUIREMENTS LISTED IN NOTE 1 ABOVE, FOUR GROUND PLATES ARE ALSO TO BE INDIVIDUALLY CONNECTED TO SEPARATE GROUND ELECTRODE CONDUCTORS IN ADDITION TO THE REBAR CONNECTIONS REQUIRED OF ALL GROUND PLATES. REFER TO UVA1.7 FOR DETAILED REBAR CONNECTION REQUIREMENTS AND REFERENCE UVA1.8 FOR POSSIBLE GROUNDING ELECTRODE CONFIGURATIONS.
- ③ INSTALL STANDARD HEX CAP SCREWS AND WASHERS (SILICON BRONZE) ON THE FOUR TERMINALS OF THE GROUND PLATES, APPLYING BURNDY'S PENTETROX E (OR SMUD APPROVED EQUIVALENT) ON ALL CONTACT SURFACES ON BOTH THE CAP SCREWS/WASHERS AND THREADED HOLES OF THE GROUND PLATE PRIOR TO INSERTING THE BOLTS.

GENERAL REQUIREMENTS:

- A1.1: ALL CONNECTIONS MUST BE AVAILABLE FOR VISUAL INSPECTION (BY A SMUD INSPECTOR) PRIOR TO POURING THE CONCRETE FLOOR.
- A1.2: ALL COMPRESSION CONNECTIONS MUST BE MADE WITH BURNDY COMPRESSION TOOLS (OR A SMUD APPROVED EQUIVALENT) AND DONE IN ACCORDANCE TO THE MANUFACTURER'S INSTRUCTION. THE PROPER DIE AND PRESSURE MUST BE USED FOR EACH CONNECTOR. ALL COMPRESSION CONNECTIONS SHALL BE INSPECTED FOR THE APPROPRIATE EMBOSSEMENT (AFTER INSTALLATION AND BY A SMUD INSPECTOR), TO ENSURE THAT THE PROPER DIE WAS USED.
- A1.3: ALL CONNECTORS MUST BE DIRECT BURIED RATED AND OF COPPER OR TINNED COPPER CONSTRUCTION.
- A1.4 ALL CONDUCTOR ENDS SHALL HAVE A MINIMUM OF 2" BEYOND THE CONNECTOR.

FIGURE A1: GROUND PLATE PLACEMENT AND SPACING DETAILS (TYPICAL)



GROUND PLATE CONNECTED TO REBAR



GROUND PLATE CONNECTED TO REBAR AND THE GROUNDING ELECTRODE (SEE REFERENCE UVA1.8 PAGES B-17B THROUGH B-17E FOR ALTERNATIVE GROUND PLATE TO GROUNDING ELECTRODE CONFIGURATIONS)

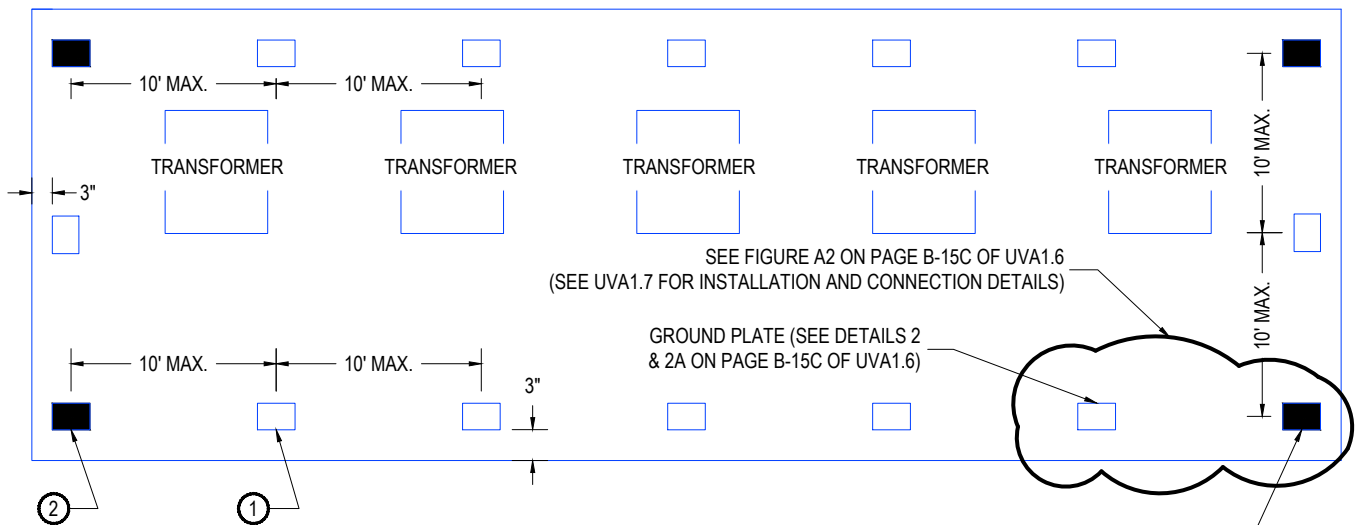

ALL CORNER GROUND PLATES ARE TO BE CONNECTED TO THE GROUNDING ELECTRODES (IN ADDITION TO THE REBAR CONNECTION) UNLESS THE ELECTRODES ARE CONFIGURED IN AN ALTERNATING MANNER (SEE REFERENCE UVA1.8 PAGES B-17B THROUGH B-17E FOR DETAILS) (SEE DETAILS 2 & 2A ON PAGE B-15C OF UVA1.6 AND UVA1.7 FOR INSTALLATION AND CONNECTION DETAILS)

PLAN VIEW
(NOT TO SCALE)

FIGURE A2: GROUND PLATE PLACEMENT DETAILS (CLOSE-UP - TYPICAL)

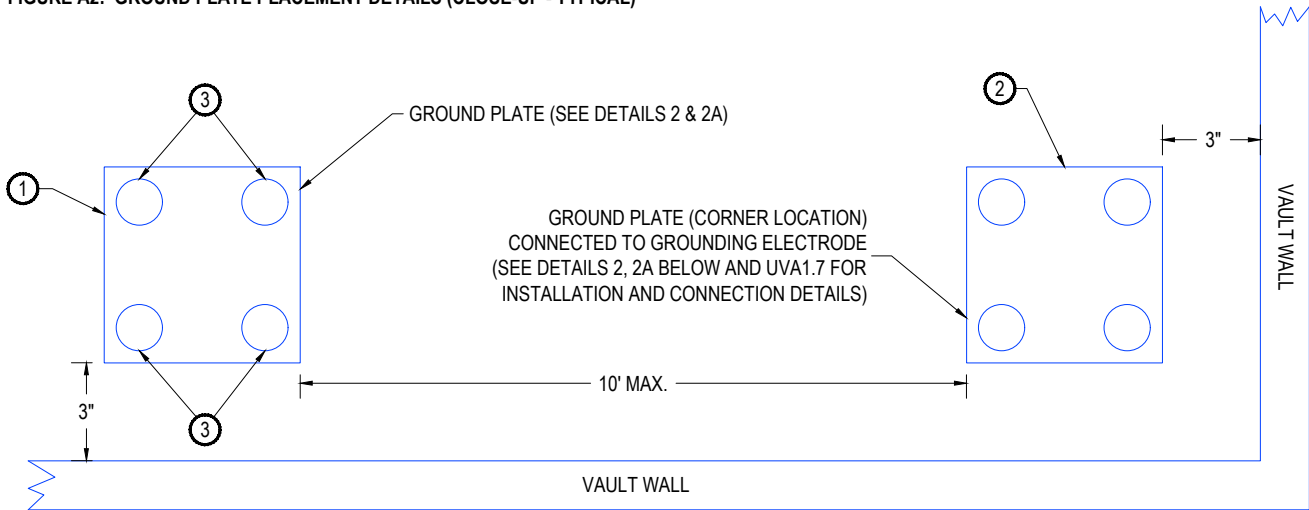

PLAN VIEW
(NOT TO SCALE)

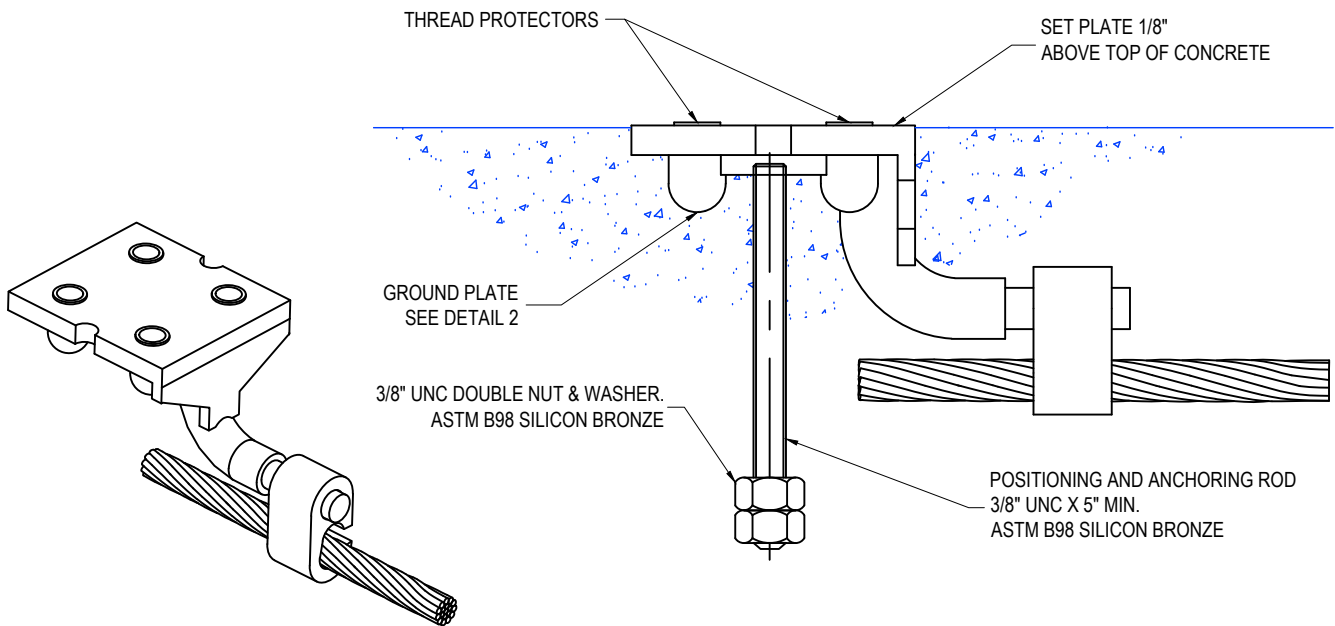

DETAIL 2

(GROUND PLATE)
BURNDY TYPE YGF OR SMUD
APPROVED EQUIVALENT SIZED FOR
500 KCMIL

DETAIL 2A

(GROUND PLATE)
POSITIONING DETAILS

NUMBERED NOTES:

- ① THE GROUNDING ELECTRODE(S) AND BONDING CONDUCTOR(S) SHALL BE 500 KCMIL BARE CU CONDUCTOR (37 STRAND, SOFT DRAWN - ASTM B3, B8) UNLESS OTHERWISE SPECIFIED.
- ② AT LEAST 20' OF THE GROUNDING ELECTRODE IS TO BE PLACED IN A COUNTERPOISED/HORIZONTAL MANNER AT LEAST 36" BELOW THE FLOOR (OR GRADE) AND AS FAR APART AS PERMISSIBLE FROM OTHER GROUNDING ELECTRODES. REFER TO REFERENCE UVA1.8 PAGES 2 THROUGH 5 FOR GROUNDING ELECTRODE LAYOUT CONFIGURATIONS. THE ENTIRE GROUNDING ELECTRODE BELOW THE FLOOR (BOTH THE HORIZONTAL AND VERTICAL PORTION) IS TO BE CONCRETE ENCASED IN AT LEAST 3" OF FULL COVER. NO INSULATING BARRIER BETWEEN THE CONCRETE AND NATIVE SOIL IS ALLOWED. SEE DETAIL 1 ON THIS REFERENCE FOR CONCRETE ENCASEMENT REQUIREMENTS. THE CONCRETE COVER CAN EXTEND TO THE FLOOR OF THE VAULT IF NECESSARY AS SHOWN IN FIGURE A3.
- ③ A JOINT COMPOUND WILL BE USED ON ALL CONNECTION POINTS (BURNDY'S PENETROX E OR SMUD APPROVED EQUIVALENT) THAT IS SUITABLE FOR COPPER TO COPPER OR COPPER TO STEEL CONNECTIONS. ENSURE ALL CONNECTION SURFACES ARE SMOOTH, CLEAN AND FREE OF RUST, PAINT, OR ANY OTHER NON-CONDUCTIVE MATERIAL AT THE CONNECTION POINT PRIOR TO THE APPLICATION OF THE JOINT COMPOUND. LIBERALLY APPLY THE COMPOUND ON ALL SURFACES TO BE CONNECTED.
- ④ COMPLETELY COAT ALL REBAR TO COPPER CONNECTORS (DETAIL 3) WITH A SMUD APPROVED, DIRECT BURIED CAPABLE SEALANT AFTER THE CONNECTION HAS BEEN MADE AND PRIOR TO POURING THE CONCRETE FLOOR. APPLY THIS SEALANT ACCORDING TO MANUFACTURER'S INSTRUCTIONS, IN ACCORDANCE TO THEIR CORROSION PROTECTION PROCEDURES.

GENERAL REQUIREMENTS:

- A2.1: ALL CONNECTIONS MUST BE MADE AVAILABLE FOR VISUAL INSPECTION (BY A SMUD INSPECTOR) PRIOR TO POURING THE CONCRETE FLOOR.
- A2.2: ALL EQUIPMENT OR TOOLS NOT EXPLICITLY OUTLINED IN THIS REFERENCE MUST BE APPROVED BY SMUD PRIOR TO INSTALLATION OR USE.
- A2.3: ALL COMPRESSION CONNECTIONS MUST BE MADE WITH BURNDY COMPRESSION TOOLS (OR A SMUD APPROVED EQUIVALENT) AND DONE IN ACCORDANCE TO THE MANUFACTURER'S INSTRUCTION. THE PROPER DIE MUST BE USED FOR EACH CONNECTOR.
- A2.4: ALL COMPRESSION CONNECTIONS SHALL BE INSPECTED FOR THE APPROPRIATE EMBOSMENT (AFTER INSTALLATION), TO ENSURE THAT THE PROPER DIE WAS USED.
- A2.5: ALL CONNECTORS MUST BE DIRECT BURIED RATED AND OF COPPER OR TINNED COPPER CONSTRUCTION.
- A2.6: ALL CONDUCTOR ENDS SHALL HAVE A MINIMUM OF 2" BEYOND THE CONNECTOR.
- A2.7: FOR ALL COPPER TO COPPER CONNECTIONS, LIBERALLY APPLY BURNDY'S PENETROX E (OR SMUD APPROVED EQUIVALENT) OVER THE CONNECTOR AFTER THE CONNECTION HAS BEEN MADE, COMPLETELY ENVELOPING THE CONNECTION POINT.
- A2.8: INSTALL STANDARD HEX CAP SCREWS AND WASHERS (SILICON BRONZE) ON THE FOUR TERMINALS OF THE GROUND PLATES. APPLY BURNDY'S PENETROX E (OR SMUD APPROVED EQUIVALENT) ON BOTH THE CAP SCREWS/WASHERS AND THREADED HOLES OF THE GROUND PLATE PRIOR TO INSERTING THE BOLTS.

FIGURE A3: REBAR CONNECTIONS (TYPICAL)

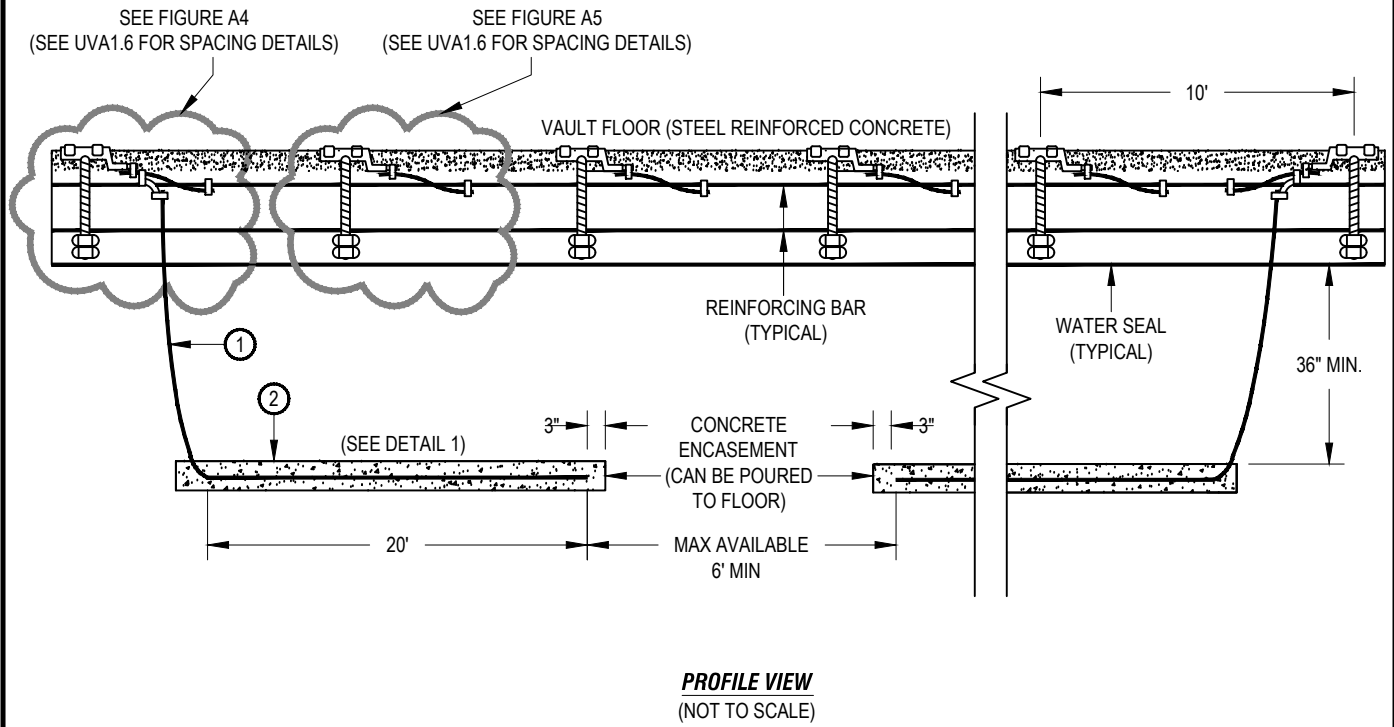

 <p>Sacramento Municipal Utility District</p>	ESR: T001	PG#: B-13	REV. DATE: NOV 2014	REV. NO.: 1	
	REBAR CONNECTION DETAILS			STANDARD NUMBER:	
				UVA 1.7	
PAGE 2 OF 4					

CONCRETE
ENCASEMENT

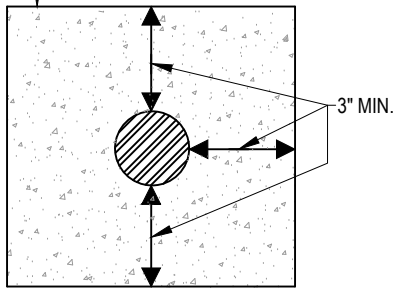

GROUNDING ELECTRODE:
500 KCMIL BARE CU

DETAIL 1
(CONCRETE ENCASED ELECTRODE)
(4 MINIMUM)

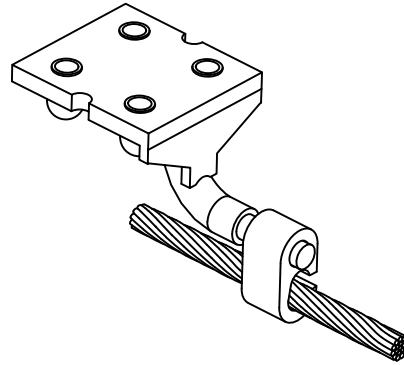

DETAIL 2
(GROUND PLATE)
BURNDY TYPE YGF OR SMUD
APPROVED EQUIVALENT
SIZED FOR 500 KCMIL

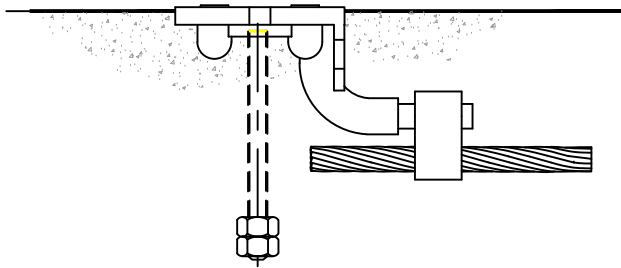

DETAIL 2A
(GROUND PLATE)
POSITIONING DETAILS

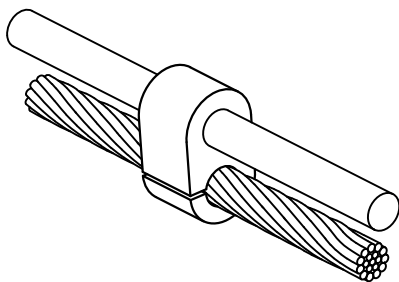

DETAIL 3
(REBAR CONNECTION) BURNDY
TYPE YGHC-C
OR SMUD APPROVED EQUIVALENT
SIZED FOR 500 KCMIL

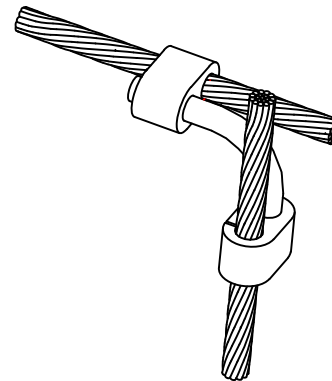

DETAIL 4
(CROSS CONNECTOR) BURNDY
TYPE YGL-C OR SMUD
APPROVED EQUIVALENT SIZED
FOR 500 KCMIL

FIGURE A4: REBAR CONNECTION DETAILS (TYPICAL)

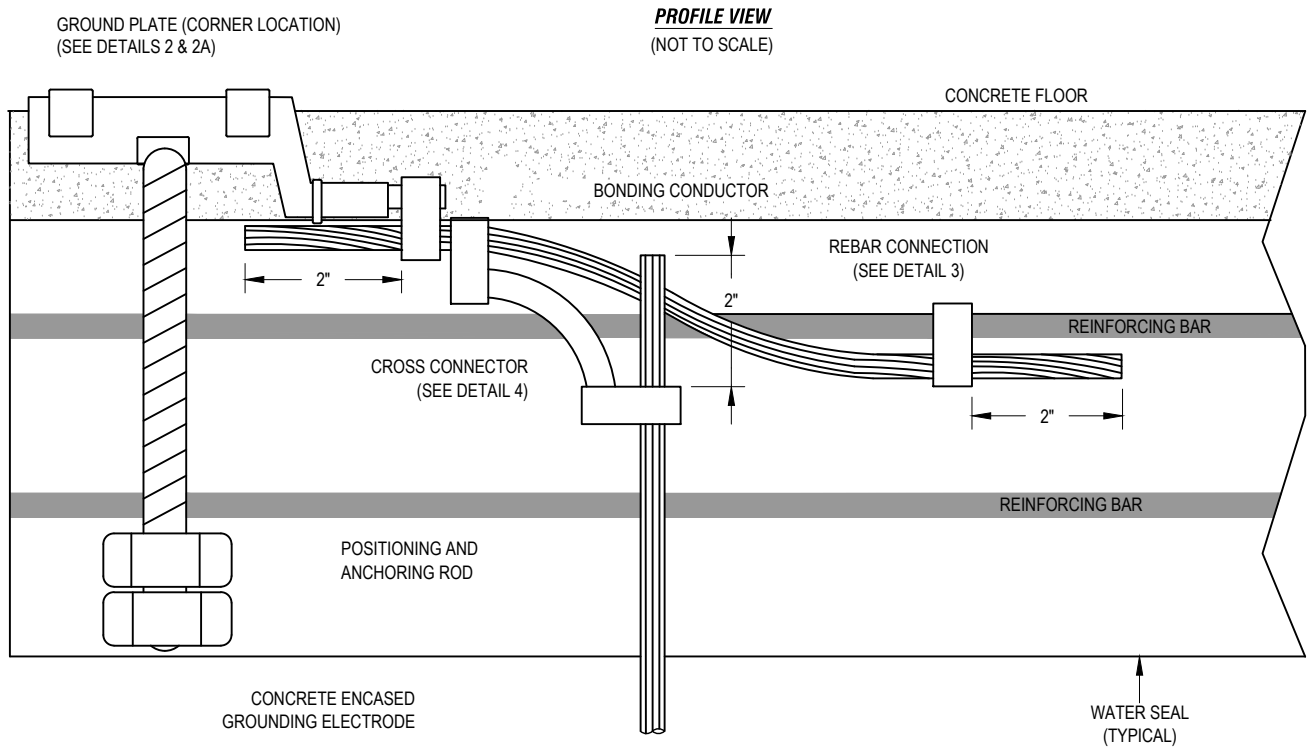
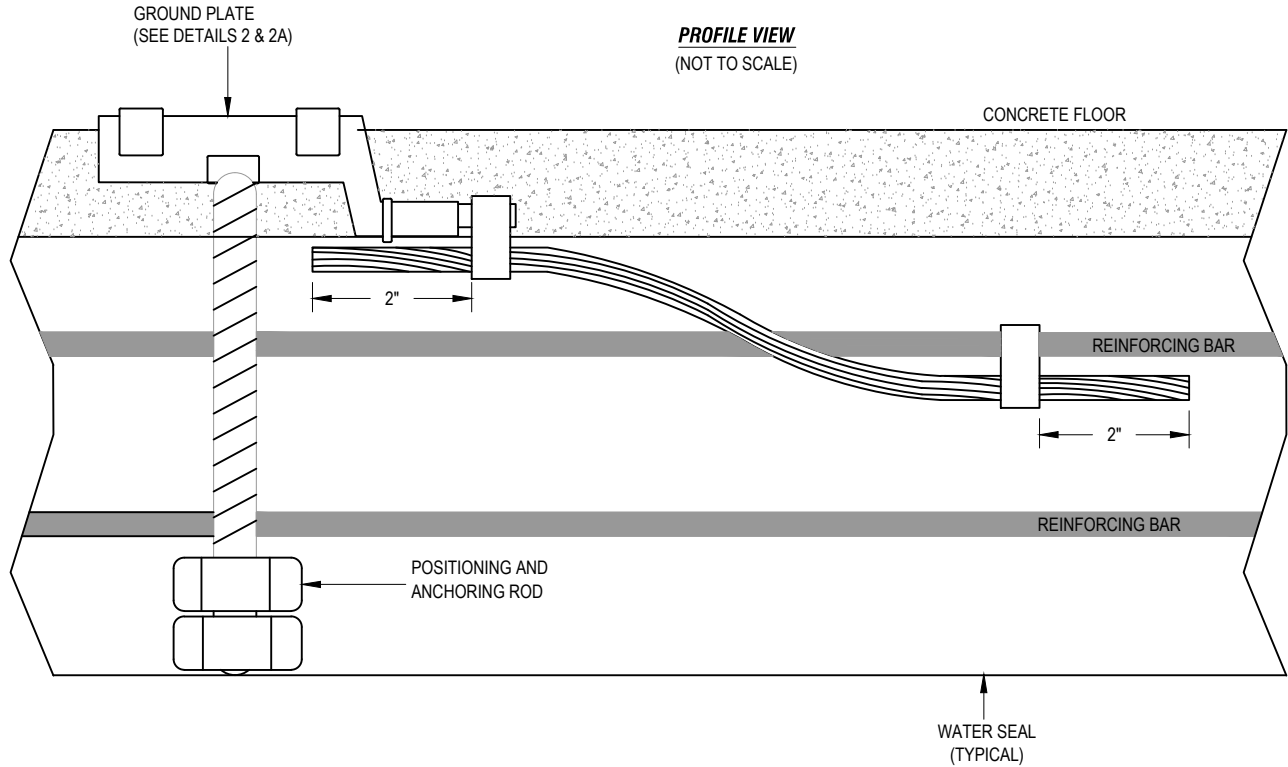

FIGURE A5: REBAR CONNECTION DETAILS (TYPICAL)



NUMBERED NOTES:

- ① REFER TO UVA1.6 FOR INSTALLATION AND CONNECTION DETAILS FOR THESE GROUND PLATES.
- ② IN ADDITION TO THE REQUIREMENTS LISTED IN NOTE 1 ABOVE, THESE FOUR GROUND PLATES ARE ALSO TO BE INDIVIDUALLY CONNECTED TO SEPARATE CONCRETE ENCASED GROUND ELECTRODE CONDUCTORS IN ADDITION TO THE REBAR CONNECTIONS REQUIRED OF ALL GROUND PLATES. REFER TO UVA1.7 FOR DETAILED REBAR CONNECTION REQUIREMENTS.

LAYOUT DESCRIPTIONS:

- A3.1: THE LOOPED CONFIGURATION CONSISTS OF THE FOUR GROUNDING ELECTRODES LAID OUT FRONT TO BACK AROUND THE PERIMETER OF THE FLOOR PLAN OF THE VAULT, WITH EACH GROUNDING ELECTRODE CONNECTED TO SEPARATE CORNER GROUND PLATES. SUFFICIENT SPACE IS REQUIRED TO ENSURE AT LEAST 1' OF SPACE EXISTS BETWEEN EACH GROUNDING ELECTRODE (FIGURE A6 AND A9).
- A3.2: THE ALTERNATING CONFIGURATION CONSISTS OF FOUR PARALLEL GROUNDING ELECTRODES, EQUALLY SPACED FROM EACH OTHER, WITH THE GROUND PLATE CONNECTIONS DONE IN AN ALTERNATING MANNER. AT LEAST TWO OF THE FOUR CORNER GROUND PLATES ARE TO BE CONNECTED TO THE GROUNDING ELECTRODES AND MUST BE LOCATED IN OPPOSITE CORNERS. THE REMAINING TWO GROUNDING ELECTRODE TO GROUND PLATE CONNECTION POINTS ARE TO BE LOCATED ALONG THE INTERIOR WALLS AS DEPICTED IN FIGURE A7.
- A3.3: THE PARALLEL CONFIGURATION CONSISTS OF FOUR GROUNDING ELECTRODES CONNECTED TO SEPARATE CORNER GROUND PLATES AND CONFIGURED PARALLEL TO THE LONGER WALL OF THE VAULT. THIS CONFIGURATION ONLY WORKS IN LARGE VAULTS AS AT LEAST 6' OF SPACING IS REQUIRED BETWEEN THE ENDS OF THE TWO IN-LINE ELECTRODES (FIGURE A8).

GENERAL REQUIREMENTS:



-  GROUND PLATE CONNECTED TO REBAR AS INDICATED IN UVA1.7
-  GROUND PLATE CONNECTED TO REBAR AND THE GROUNDING ELECTRODE AS INDICATED IN UVA1.7
-  CONCRETE ENCASED GROUNDING ELECTRODE PLACED AT LEAST 3' BELOW GRADE AS INDICATED IN UVA1.7

FIGURE A6: LOOPED CONFIGURATION (SEE NOTE A3.1)



PLAN VIEW
(NOT TO SCALE)

FIGURE A7: ALTERNATING CONFIGURATION (SEE NOTE A3.2)

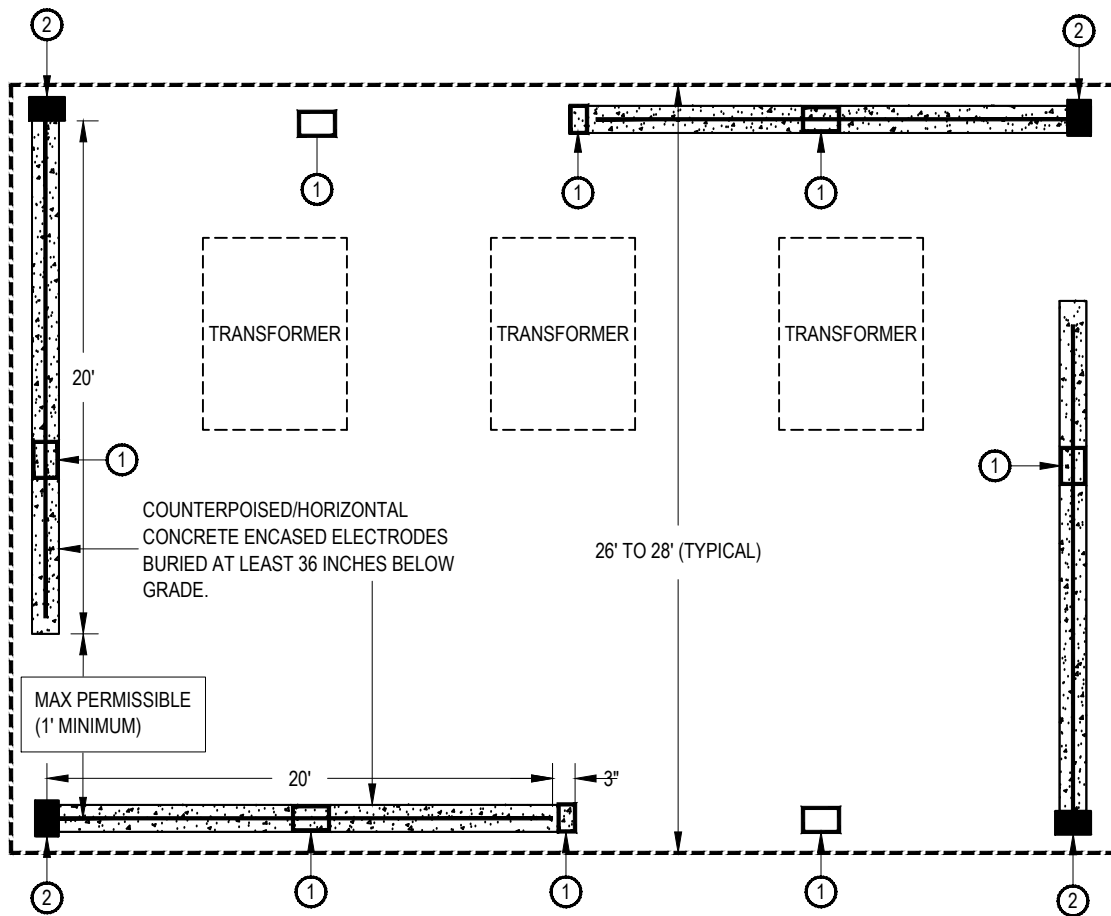
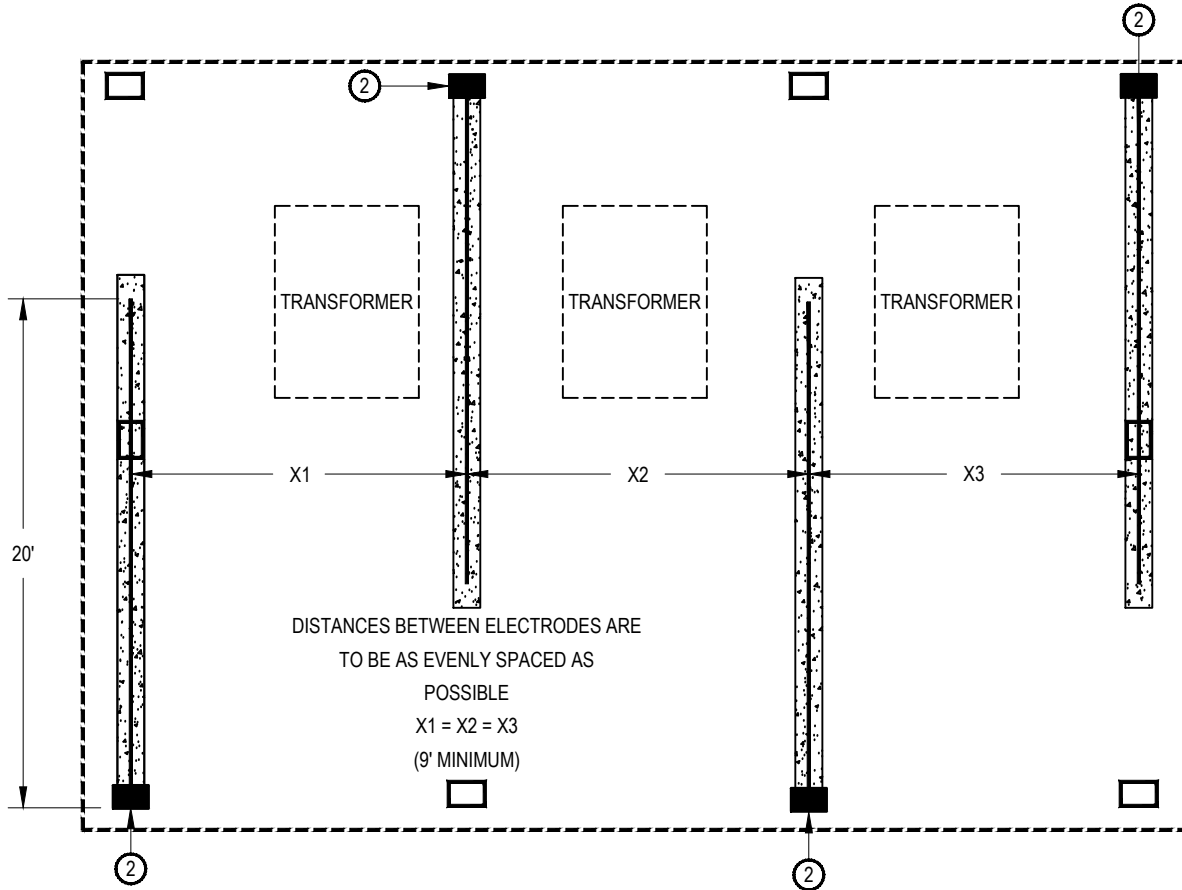

PLAN VIEW
(NOT TO SCALE)

FIGURE A8: PARALLEL CONFIGURATION (LARGE VAULT)(SEE NOTE A3.3)

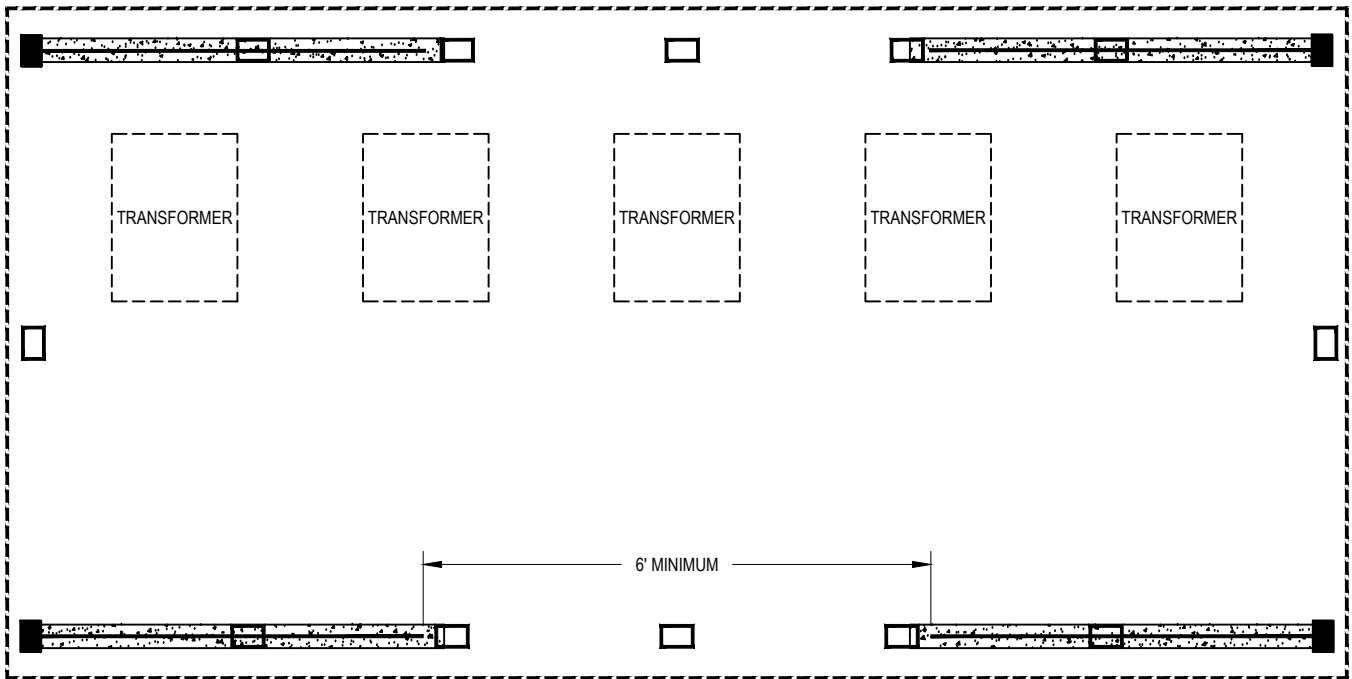

PLAN VIEW
(NOT TO SCALE)

FIGURE A9: LOOPED CONFIGURATION (LARGE VAULT) (SEE NOTE A3.1)

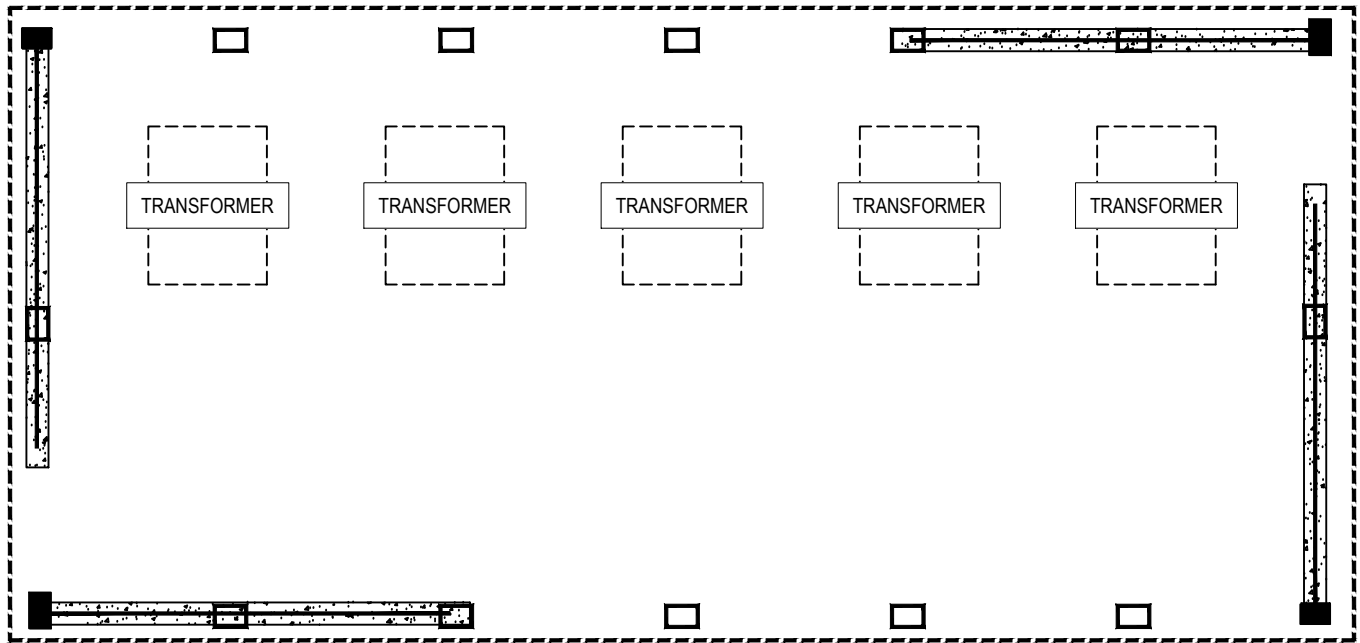

PLAN VIEW
(NOT TO SCALE)

