



## Electric Service Requirements

---

# Residential Underground Engineering Specification T003

---

October 2024



	<b>ENGINEERING SPECIFICATION</b>	No. <b>T003</b> Page 1 of 19	
		REV. <b>9</b>	DATE: <b>10/24</b>
CATEGORY <p style="text-align: center;"><b>ELECTRIC SERVICE REQUIREMENT</b></p>			
SUBJECT: <p style="text-align: center;"><b>Residential Underground</b></p>			

## Table of Contents

<b>1</b>	<b>GENERAL REQUIREMENTS FOR SERVICE .....</b>	<b>2</b>
<b>2</b>	<b>ABBREVIATIONS .....</b>	<b>3</b>
<b>3</b>	<b>MINIMUM REQUIREMENTS FOR RESIDENTIAL UNDERGROUND INSTALLATIONS .....</b>	<b>4</b>
	<b>3.1 Metering .....</b>	<b>4</b>
	<b>3.2 Multiple Meter Installations .....</b>	<b>5</b>
	<b>3.3 Meter Cabinets and Enclosures .....</b>	<b>6</b>
	<b>3.4 Service Riser Conduit .....</b>	<b>6</b>
	<b>3.5 Non-Concrete Underground Enclosures.....</b>	<b>7</b>
	<b>3.6 Full Traffic underground enclosures .....</b>	<b>7</b>
	<b>3.7 Service Main Disconnect .....</b>	<b>8</b>
	<b>3.8 Grounding .....</b>	<b>8</b>
	<b>3.9 Non-installation of Meters .....</b>	<b>8</b>
	<b>3.10 Transformer Clearances .....</b>	<b>9</b>
<b>4</b>	<b>SPECIAL REQUIREMENTS FOR RESIDENTIAL UNDERGROUND SERVICE .</b>	<b>9</b>
	<b>4.1 Single Family through 6-plex dwellings - Non-Subdivision.....</b>	<b>9</b>
	<b>4.2 Multi-Family Dwellings - Seven Units or More .....</b>	<b>10</b>
<b>5</b>	<b>SWIMMING POOL CLEARANCES FOR SUPPLY SERVICE DROPS, (INCLUDES HOT TUBS).....</b>	<b>11</b>
<b>6</b>	<b>CUSTOMER FURNISHED AND INSTALLED SERVICE REQUIREMENTS FOR RESIDENTIAL SUBDIVISIONS WITH CONTRACTS EXECUTED AFTER</b>	<b>11</b>
	<b>Appendix B: List of Material Suppliers .....</b>	<b>17</b>
	<b>Appendix C: Design and Construction Drawings .....</b>	<b>18</b>
	<b>Appendix D: EUSERC Drawings.....</b>	<b>19</b>

 ENG. SPEC. <b>T003</b>	<b>REV.</b> <b>9</b>	<b>Residential Underground</b>	<b>Page</b> <b>2 of 19</b>
--	-------------------------	--------------------------------	-------------------------------

## 1 GENERAL REQUIREMENTS FOR SERVICE

- 1.1. This is a guide to the Sacramento Municipal Utility District's (SMUD's) requirements for the establishment of electric service to new Residential underground installations or rewired, remodeled or a revision to existing Residential underground installations. The requirements presented here are necessary for SMUD to supply uniform, satisfactory and safe service. It is necessary that all written material (this text, as well as all the notes on the drawings) be carefully read.
- 1.2. It is important that satisfactory arrangements be made for the installation of electric service lines and the location and setting of meters. Customers must notify SMUD of any planned or intended changes in the load, character or nature of the service required to supply the premises, structure, building, or other facility. For new, replacement, rewire or upgrade of electric service go to [www.smud.org/projectapplication](http://www.smud.org/projectapplication) or contact SMUD's Customer Services Department, 6301 S Street, (888) 742-7683 (SMUD).
- 1.3. Notification to SMUD must be accomplished as soon as initial planning is considered. Delays in supplying the required information could cause an unnecessary inconvenience or delay for the customer.
- 1.4. If the customer fails to notify SMUD and the changes exceed the capability of the installed utility service, metering, or other equipment and damage those facilities, the Customer is liable for all damages and resultant costs to SMUD.
- 1.5. Electric service will NOT be established until the "service entrance facilities" are satisfactorily completed by the customer and approved by the appropriate agency having jurisdiction.  
  
NOTE: "Customer service entrance facilities" is the term used to designate all the electrical components required to be furnished and installed by the customer and could include service boxes or conduits. SMUD will furnish, install and maintain the current transformers and meters.
- 1.6. For technical questions regarding new Residential underground installations or rewired, remodeled and/or a revision to existing Residential underground installations, contact SMUD Line Design Department at (916) 732-5700.
- 1.7. Where the operation of the customer's equipment will require unusually stable voltage regulation free from momentary and transient voltage excursions, or other stringent voltage control beyond that supplied by SMUD in the normal operation of its system, the customer, at his/her own expense, shall be responsible for installing, owning, operating and maintaining any special or auxiliary equipment on the load side of the meter that will be required, as deemed necessary by the customer, for the operation of the customer's equipment.

- 1.8. All materials used and all work performed on a customer's premise, with the exception of the meter and service (if installed by SMUD), must conform with local inspection authority requirements. No service can be connected unless approved by the agency having jurisdiction. Only authorized SMUD employees are permitted to make connections between SMUD wiring and customer wiring.
- 1.9. The SMUD commitment letter will normally be valid for one year. A new SMUD commitment will normally be required after one year unless a customer has requested and received written approval for a longer period of time from a SMUD Engineering Designer.
- 1.10. In addition to SMUD requirements, the customer is responsible for complying with applicable provisions of City and County ordinances, the "National Electric Code" and all applicable orders, rules and regulations of the State of California. All meter panel and customer service switchboard equipment shall meet SMUD and EUSERC requirements and be UL approved.
- 1.11. Plot plans should be furnished to SMUD at 4401 Bradshaw Rd. Sacramento, CA 95827-3834 as soon as possible. Delays in supplying the required information could cause an unnecessary inconvenience for the customer.
- 1.12. The customer's service voltage will be determined by SMUD's Line Design Department. Normally, only one service point will be granted to one building or one parcel of property. Multiple service points may be granted to one building or multiple buildings on one parcel, provided they meet the requirements of the "National Electric Code" as well as the requirements of SMUD and the agency having jurisdiction. When additional meters are added for nonresidential usage it will be at a general service rate, and subject to monthly service charges.
- 1.13. Failure to comply with the above procedures could be costly and cause unnecessary delays and/or costs for the customer.

## 2 ABBREVIATIONS

The following abbreviations are used throughout this Electrical Service Requirement:

A or Amp = Amperes	MCM = Thousand Circular Mills (kcmil)
AL = Aluminum	Min = Minimum
AWG = American Wire Gauge	PG&E = Pacific Gas & Electric
DB = Direct Burial	PUE = Public Utility Easement
EUSERC = Electric Utility Service Equipment Requirements Committee	PVC = Polyvinyl Chloride
L = Length	TYP = Typical
Max = Maximum	UL = Underwriters Laboratory
	V = Volts
	W = Width

 ENG. SPEC. <b>T003</b>	<b>REV.</b> <b>9</b>	<b>Residential Underground</b>	<b>Page</b> <b>4 of 19</b>
--	-------------------------	--------------------------------	-------------------------------

**USE CAUTION WHEN  
DIGGING TO AVOID  
BURIED ELECTRICAL CABLES.  
BEFORE DIGGING CALL  
U.S.A. (Underground Service Alert),  
800-227-2600 or 811**

### **3 MINIMUM REQUIREMENTS FOR RESIDENTIAL UNDERGROUND INSTALLATIONS**

#### **3.1 Metering**

##### **3.1.1 Meter Locations**

- 3.1.1.1 All meter locations must be approved by a SMUD Engineering Designer. Call (888) 742-7683 (SMUD) to request a meter spot.
- 3.1.1.2 Meter spots for all installations will be designated by a SMUD Engineering Designer. The meter(s) shall be located within 6 feet of the corner of the building closest to the SMUD service point and shall be a minimum of 3 feet from all property lines. Meter locations other than described above will NOT be allowed without advance written permission from a SMUD Engineering Designer. Any deviations will be made only for special structural requirements and must be approved by the SMUD Engineering Designer. Meter locations other than those described above are subject to additional charges, payable prior to meter installation.
- 3.1.1.3 A level standing and working surface of 36"L X 30"W shall be provided in front of each meter, permitting ready access to the meter (See drawing C-1).
- 3.1.1.4 Meters may be located in locked rooms, cabinets or fenced enclosures only after approval of a SMUD Engineering Designer. Access by SMUD representatives to such areas shall be obtainable by using a SMUD key. The customer is responsible for having the lock keyed for a SMUD key.
- 3.1.1.5 Carports, breezeways, covered or screened porches and patios, or any other area that might be enclosed at some future date, shall NOT be selected as a meter location.
- 3.1.1.6 Meters or metering equipment shall NOT be installed in elevators, ventilator shafts, clothes closets, broom closets, lavatories, in or over stairways, over doorways, windows, sinks, wash trays, gas meters or other grounded objects, in driveways, or in any other hazardous location.
- 3.1.1.7 The area on either side of an out swinging door or swinging window, which is equal to the width of that door or swinging window, is NOT acceptable as a meter location.

3.1.1.8 See Pages C-1, C-2 and C-7 for details and clearance requirements.

### 3.1.2 Meter Socket

3.1.2.1 The meter socket must be installed in a true, vertical plane.

3.1.2.2 Any unused outlets in meter sockets must be sealed with internally removable plugs.

3.1.2.3 Die-cast meter sockets shall NOT be used.

3.1.2.4 Residential, self-contained meter sockets shall be UL approved, must meet EUSERC standards, and shall have a maximum current rating equal to, or greater than, the current rating of the associated load service equipment.

3.1.2.5 Neutral taps shall be connected to the service neutral conductor and located behind sealed panels. Wire nuts are NOT permitted.

3.1.2.6 Meter sockets with extruded or cast aluminum jaws are NOT acceptable and will NOT be connected.

3.1.2.7 Sockets for residential installations should NOT be equipped with test bypass devices.

3.1.2.8 All Meter Sockets shall be ring type.

### 3.1.3 Metering Arrangement

3.1.3.1 The metering arrangement approved as standard and required by SMUD provides for the line current to enter first the meter and then the customer's service main disconnect and/or overload protective devices (fuses or circuit breakers).

3.1.3.2 Metered and unmetered wires shall be run in separate conduits, raceways or wiring gutters and are not permitted to either be in the service termination box/can or compartment.

### 3.1.4 Metering Residential Services in Excess of 225 Amps

3.1.4.1 See Pages D-5 and D-6 for requirements on service panels greater than 225 Amps.

### 3.2 Multiple Meter Installations

3.2.1 All apartment "house" or commercial use meters require test bypass devices.

3.2.2 Plastic meter covers will be used to cover energized sockets only if the socket is installed for future use. Where extra meter sockets have been installed in multi-meter installations and have no probable future use, the customer must remove the internal bus from the socket and permanently close and seal the socket opening.

3.2.3 For multiple-meter installations, the meter sockets shall have a minimum horizontal clearance of 7 ½", center to center, and a minimum vertical clearance of 8 ½", center to center.

- 3.2.4 Meters should be grouped together.
- 3.3 Meter Cabinets and Enclosures
  - 3.3.1 The cabinet shall be so designed that the roof, doors and the roof or door supports will NOT interfere with the installation of the meter.
  - 3.3.2 Shallow cabinets, with holes cut in the door for meters to protrude through, will NOT be permitted.
  - 3.3.3 Clearances between the sealing flanges of the meter sockets and the inside of a closed cabinet door shall be:
    - 3.3.3.1 Seven-inch (7") minimum for an apartment meter
    - 3.3.3.2 Nine-inch (9") minimum for apartment "house" meters(See SMUD Drawing C-7 for details)
  - 3.3.4 Hinged doors shall NOT exceed 4' x 4' and shall be fabricated with a positive locking device to hold them in the open position safely.
  - 3.3.5 All doors shall be fitted properly to ensure positive opening and closing and shall be equipped with adequate pulls, hinges and latches.
  - 3.3.6 All cabinets exposed to the weather shall be rain-tight and constructed of weather resistant materials. All top openings (conduits entering and leaving) shall be flashed and sealed.
  - 3.3.7 When cabinets are to be locked with the customer's lock, a double lock arrangement shall be provided by the customer to accommodate a SMUD padlock.
- 3.4 Service Riser Conduit
  - 3.4.1 Minimum size will be 2" SCH 40 PVC or equivalent for flush installations. Surface mounted or exposed conduit installations will require SCH 80 PVC. See Pages C-4 and C-5 for conduit requirements.
  - 3.4.2 Conduit shall be a continuous run, flush or surface mounted from elbow at foundation line to meter socket. If gutters are required, they must be approved by SMUD's Line Design Department and shall be equipped with approved sealing devices.
  - 3.4.3 Fire protection, in accordance with local inspection authorities, is required where service risers are enclosed in flammable materials.
  - 3.4.4 Conduit may be concealed in building walls on the Utility (line) side of the meter under the following conditions:
    - 3.4.4.1 A semi-flush mounted, combination meter socket and service main disconnect is used.
    - 3.4.4.2 A 2" minimum inside diameter conduit is used.

 ENG. SPEC. <b>T003</b>	<b>REV.</b> <b>9</b>	<b>Residential Underground</b>	<b>Page</b> <b>7 of 19</b>
--	-------------------------	--------------------------------	-------------------------------

3.4.4.3 Conduit is in one continuous vertical run from the meter service entrance to a minimum of 6" below where the conduit leaves the concealed wall. No conduits or sleeves are allowed in the concealed area.

3.5 Non-Concrete Underground Enclosures

3.5.1 Secondary boxes shall be installed per SMUD drawing C-4 and C-5, latest revision.

3.5.2 Enclosures and extensions shall meet ANSI TIER 15 loading requirements.

3.5.3 The approved manufacturers and part numbers for the **17" x 30" x 18" Enclosures** are:

<b>Hubbell</b>	A52173051305D
<b>Replacon</b>	RP1730-18-IT
<b>Armorcast Products</b>	A6001640TAX18
<b>NewBasis</b>	FCA173018T-90015
<b>Martin Enterprises</b>	173018 FRP SMUD
<b>Oldcastle</b>	CTA173018HA837X000

3.5.4 The approved manufacturers and part numbers for the **17" x 30" x 8" Extensions** are:

<b>Armorcast Products</b>	A6001640TEX8
<b>Hubbell</b>	E02173008A
<b>NewBasis</b>	FCE073008T-00000
<b>Martin Enterprises</b>	173008 FRP EXT SMUD
<b>Oldcastle</b>	CTX173008H0000X000

3.5.5 Customer pull boxes and/or other openable devices are not allowed in the service run between the SMUD service box and customer's panel.

3.5.6 When the service box is installed at an elevation above the bottom of the meter panel the Customer or Contractor must provide a means to discharge any excess water or water pressure from the conduit system. This can be achieved by installing a "Flo Saddle" or conduit "Y" with appropriate reducer and angled coupling to drain water to the exterior (see C-18).

3.6 Full Traffic underground enclosures

**3.6.1** Open Bottom Concrete Boxes, Extensions, and Steel Covers (17" x 30", See U1S3X5)

3.6.2 These boxes, extensions, and covers shall be rated for full deliberate H20-44 heavy traffic loading. These boxes shall be installed in full traffic locations and incidental traffic locations such as parking lots, alleys, and industrial areas.

3.6.3 "SMUD ELECTRIC" shall be marked on top of cover with 1" minimum height letters, and 3/8" or 1/2" large penta-head stainless steel bolts.



 ENG. SPEC. <b>T003</b>	<b>REV.</b> <b>9</b>	<b>Residential Underground</b>	<b>Page</b> <b>8 of 19</b>
--	-------------------------	--------------------------------	-------------------------------

3.6.4 The approved manufacturers and part numbers for the 17" x 30" x 12" Box, Extension, and Cover are:

3.6.4.1 **Jensen Precast** HT1730-B; with corresponding cover, HT1730-L01; with corresponding extension, HT1730-E12.

3.6.4.2 **Concast** CHR-17-30-12; with corresponding cover, 17-30-CHR-TP; with corresponding extension, CHREX-17-30-12.

3.6.4.3 **Oldcastle**; 1000295; with corresponding cover, 2001810; with corresponding extension, 1000300.

### 3.7 Service Main Disconnect

3.7.1 The service main disconnect must be installed on the customer's (load) side of the SMUD meter.

3.7.2 All service switches must be approved by SMUD's Meter Department and local inspection authorities.

3.7.3 If the switch is installed outside, it must be an approved, rain-tight type.

3.7.4 A customer's service main disconnect, or main breaker, will normally be installed within 10' of where the service enters the building structure. Special permission of SMUD and the local inspection authority must be obtained to increase this distance.

3.7.5 Whether the service main disconnect is immediately adjacent to the meter socket or not, the wiring between the two must be in an approved conduit. Sealable gutters are allowed only with the prior approval of SMUD's Line Design Department and the local inspection authority.

3.7.6 The local inspection authority must be consulted for required service main disconnect or main breaker size.

### 3.8 Grounding

3.8.1 An approved concrete encased electrode (Ufer ground) must be used for all new construction and remodeling (Per "National Electric Code").

3.8.2 The local inspection authority must be consulted for ground conductor and type.

3.8.3 The connection between customer ground and customer service equipment must be visible to SMUD and local inspection authority.

### 3.9 Non-installation of Meters

The meters will **NOT** be installed until the customer has complied with all the requirements noted above **and**:

3.9.1 The work has been approved by SMUD and the appropriate inspecting authority.

 <p><b>SMUD</b> ENG. SPEC. <b>T003</b></p>	<p><b>REV.</b> <b>9</b></p>	<p align="center"><b>Residential Underground</b></p>	<p align="right"><b>Page</b> <b>9 of 19</b></p>
---	---------------------------------	--	---

3.9.2 Each service main disconnect and meter position, in a multiple meter installation, has been clearly and prominently marked in a permanent manner with an engraved plate which has been fastened with stainless-steel screws, to indicate the particular address supplied by each meter. Street addresses, suite/apartment numbers, etc., identifiable to the appropriate meter, shall be permanently affixed to the building.

3.10 Transformer Clearances

3.10.1 All clearances shall be per UVD2.1A.

3.10.2 An eight (8) foot clearance shall be maintained in front of the transformer pad, clear from objects or structures.

3.10.3 A minimum three (3) foot clearance shall be maintained on the transformer pad side or sides.

3.10.4 Tress shall not be planted, or grown, within eight (8) feet of the transformer pad.

**4 SPECIAL REQUIREMENTS FOR RESIDENTIAL UNDERGROUND SERVICE**

4.1 Single Family through 6-plex dwellings - Non-Subdivision

These installations will be served under provisions of SMUD Rules and Regulations 15.

4.1.1 Services

4.1.1.1 SMUD shall furnish the service conductors.

4.1.1.2 For new service extensions the customer shall provide the service trench, conduit, backfill, compaction, and the required termination point. The required termination point at the service entrance location must be installed prior to installation of SMUD's conductors.

4.1.1.3 Where the customer is upgrading, replacing or relocating electric service facilities for single-phase 120/240V service please see C-16.

4.1.2 Trenching

4.1.2.1 One trench must be provided for each service.

4.1.2.2 In no case is a customer or contractor to dig under a SMUD transformer pad.

4.1.2.3 As required the customer or contractor shall trench up to a SMUD temporary service conduit, pedestal, pole, or other service point as determined by the SMUD Engineering Designer.

4.1.2.4 The trench shall provide for a minimum 30" of conduit cover (35" near the SMUD service box). Minimum trench width is 6" and may have to be increased to provide for other utility conduits. A minimum 17" x 30" x 18" hand hole must be provided at SMUD's service point. This may need to be increased to 30" x 48" x 18" to provide adequate access.

 <p><b>SMUD</b> ENG. SPEC. <b>T003</b></p>	<p><b>REV.</b> <b>9</b></p>	<p align="center"><b>Residential Underground</b></p>	<p align="right"><b>Page</b> <b>10 of 19</b></p>
---	---------------------------------	--	--

4.1.2.5 Where the customer has installed obstructions or extensive landscaping over SMUD's service conductors, and it is necessary for SMUD to replace or repair the service conductors in that area, the customer may be required to relocate the service trench and furnish new trench/conduit out of the affected area.

4.1.2.6 Compaction shall meet City, County, SMUD, and/or State requirements.

4.1.2.7 See Pages C-3 and C-4 for trenching details.

#### 4.1.3 Conduit

4.1.3.1 PVC type DB 120 (ANSI/ASTM-F512-gray in color) or better conduit shall be used for all customer furnished service conduit installations.

4.1.3.2 All electrical conduit exposed above ground shall be a minimum Schedule 80 PVC or equivalent. All elbows shall be a minimum Schedule 40 PVC or equivalent. Conduits, within the building walls, shall be a continuous run and shall be a minimum Schedule 40 PVC or equivalent.

4.1.3.3 The customer must notify SMUD five (5) full working days in advance of covering any conduit so that an inspection can be made. For trench inspections, call (916) 732-5990. If the trench is backfilled before the conduit is inspected, the customer will be required to pothole in order to verify the depth and type of conduit.

4.1.3.4 A "sleeper" rope or flat pull tape (2,500 lb. test) must be installed in all conduits. It must extend to the surface when the conduit is covered. The open end of a buried conduit must be capped in such a manner that it prohibits dirt from entering (See Page C-15).

4.1.3.5 Water pipe or water type PVC is NOT approved for any electrical installation.

4.1.3.6 A maximum of three 90° elbows, or 270° total, will be allowed in any one service run. A minimum of 10" must separate all 45° or 90° elbows in the conduit run. Conduits will have the following minimum radius: 2" diameter - 18" radius, 3" diameter - 18" radius, 4" diameter - 30" radius.

4.1.3.7 See Pages C-4 and C-5 for installation and size details.

#### 4.2 Multi-Family Dwellings - Seven Units or More

These installations will be served under provisions of SMUD Rules and Regulations 16.

 ENG. SPEC. <b>T003</b>	<b>REV.</b> <b>9</b>	<b>Residential Underground</b>	<b>Page</b> <b>11 of 19</b>
--	-------------------------	--------------------------------	--------------------------------

4.2.1 Services

4.2.1.1 All materials used in this service installation, with the exception of the meters & current transformers, will be furnished and installed by the customer and shall conform to the requirements of SMUD and the local agency having jurisdiction.

4.2.2 Conduit

4.2.2.1 The customer will furnish and install all conduit(s) as required for SMUD's conductors.

4.2.2.2 The customer will furnish and install all required pads, boxes and wells, as well as all primary and secondary pull boxes required under provisions of SMUD's Engineering Specification T007 - Distribution Underground Structure.

**5 SWIMMING POOL CLEARANCES FOR SUPPLY SERVICE DROPS, (INCLUDES HOT TUBS)**

The clearances shown on Page C-10 are required in SMUD's service area.

**6 CUSTOMER FURNISHED AND INSTALLED SERVICE REQUIREMENTS FOR RESIDENTIAL SUBDIVISIONS WITH CONTRACTS EXECUTED AFTER JANUARY 1, 1989**

See Pages C-13 and C-14 for requirements on Customer Furnished and Installed Services.

For conductor requirements, see Appendix A: SMUD Electric System Design Department Specification No. DS1004 (Formerly D004), 600 Volt, Aluminum Single Conductor Power Cable.

 ENG. SPEC. <b>T003</b>	<b>REV.</b> <b>9</b>	<b>Residential Underground</b>	<b>Page</b> <b>12 of 19</b>
--	-------------------------	--------------------------------	--------------------------------

**SMUD Electric System Design Department Specification No. DS1004  
600 Volt, Aluminum Single Conductor Power Cable**

## **1 PURPOSE**

This Engineering Specification is used to provide the manufacturing requirements of a single conductor, and two, three and four-wire cable systems consisting of insulated aluminum cables duplexed, triplexed or quadruplexed on a reel. These cables shall be suitable for either direct burial or for duct installation in wet or dry applications.

## **2 SCOPE**

This specification applies to all 600 volt class, aluminum single conductor, duplex, triplex, or quadruplex underground cables used in SMUD. All work and material to design, fabricate, test, package, and deliver the specified equipment along with any drawings, manuals, or other documents required shall be provided by the successful bidder.

## **3 REFERENCES** LATEST EDITIONS, ERRATA, CORRECTIONS, BULLETINS, AND AMENDMENTS

- 3.1** Insulated Cable Engineers Association (ICEA) Standards Publication No. S-105-692, 600V Single Layer Thermoset Insulated Utility Underground Distribution Cable.
- 3.2** ICEA Standards Publication No. S-81-570, 600 Volt Rated Cables of Ruggedized Design For Direct Burial Installations as Single Conductors or Assemblies of Single Conductors.
- 3.3** ASTM B230, Standard Specification for Aluminum 1350-H19 Wire for Electrical Purposes,.
- 3.4** ASTM B231, Standard Specification for Concentric Lay Stranded Aluminum 1350 Conductors, Latest Edition.
- 3.5** UL 854, Service-Entrance Cables
- 3.6** The Aluminum Association 49, Code Words for Underground Distribution (UD) Cables.
- 3.7** NEMA Standards Publication No. WC 26, Binational Wire and Cable Packaging Standard.

## **4 DEFINITIONS**

Refer to the IEEE Standard Dictionary of Electrical and Electronic Terms and the references in section 3.

## 5 SPECIFICATIONS

### 5.1 GENERAL

- 5.1.1 The cable shall be manufactured in accordance with UL 854 for Type USE-2 applications.
- 5.1.2 The cable neutral and phase conductors shall be thermoset single layer cross-linked polyethylene Type I insulation in accordance with ICEA S-105-692 preferred, or a thermoset single or dual layer composite or extrudable cross-linked polyethylene insulation in accordance with ICEA S-81-570 for 90 degrees C as an acceptable alternative. Suppliers may provide the lower cost between these two designs.
- 5.1.3 The cable shall be designed for a normal maximum operating temperature of 90 degree C and be suitable for operation at this temperature in dry and wet locations, and in direct buried or duct installations.
- 5.1.4 If discrepancies are determined between these specifications, the issues shall be addressed with the SMUD Principal Design Engineer – Standards. In general, the more conservative shall apply.
- 5.1.5 The specific requirements such as the size and number of conductors as well as the quantity (length) shall be defined in the bid document. Some of the SMUD cables for which this specification is written are shown in the table below.

Stock Code	Number of Phase Conductors - Size	Neutral Conductor	Code Word
10010033	2 – 750 KCMIL AL	350 KCMIL AL	Villanova / XLP
10000225	2 - 350 KCMIL AL	#4/0 AWG AL	Wesleyan / XLP
10022751	3 - #4/0 KCMIL AL	#2/0 AWG AL	Wake Forest / XLP
10002025 10023036	2 - #4/0 AWG AL	#2/0 AWG AL	Sweetbriar / XLP
10024954	2 - #1/0 KCMIL AL	#2 AWG AL	Brenau / XLP
10002024	2 - #2/0 AWG AL	#1 AWG AL	Converse / XLP
10002023	2 - #2 AWG AL	#4 AWG AL	Stephens / XLP
10011595	3 - #2 AWG AL	#4 AWG AL	Dyke / XLP
10000191	1 - #6 AWG AL	#6 AWG AL	Clafin / XLP

 <p><b>SMUD</b> ENG. SPEC. <b>T003</b></p>	<p><b>REV.</b> <b>9</b></p>	<p align="center"><b>Residential Underground</b></p>	<p align="right"><b>Page</b> <b>14 of 19</b></p>
---	---------------------------------	--	--

## **5.2 CONDUCTOR**

- 5.2.1 The conductor size and number shall be defined in the bid document and meet the requirements of UL 854 and either ICEA S-105-692 or ICEA S-81-570.
- 5.2.2 The conductors shall be Aluminum 1350-H19 wire in accordance with ASTM B 230.
- 5.2.3 Conductors shall be round concentric Class B stranded, or compressed Class B stranded in accordance with ASTM B231.
- 5.2.4 A separator tape between the conductor and insulation per ICEA S105-692 or ICEA S-81-570 may be used if determined needed by the manufacturer.

## **5.3 INSULATION**

- 5.3.1 The insulation of the phase conductor and neutral conductor shall be composed of either
  - 5.3.1.1 a single layer of low-density cross-linked polyethylene meeting the Type I requirements per ICEA Standards No. S-105-692 or
  - 5.3.1.2 an inner layer of low/medium density polyethylene and an outer layer of black high-density polyethylene rated 90 degrees C Normal Service Operation Insulation per ICEA S-81-570. The two-layer insulation shall be firmly bonded together and simultaneously cross-linked.
- 5.3.2 The insulation shall also meet the requirements of UL 854 for Type USE-2 applications.
- 5.3.3 The average thickness of the insulation shall be per ICEA S-105-692 for a single layer insulation system, or ICEA S-81-570 for the composite insulation system.
- 5.3.4 In all cases, the outer insulation of the phase conductor shall be black and the neutral conductor shall be black with extruded yellow stripe for identification.

## **5.4 CABLE LABELING**

- 5.4.1 The labeling on the outer insulation or cable jacket shall be performed in accordance with the requirements of UL 854 and either ICEA S-105-692 or ICEA S-81-570 as applicable.
- 5.4.2 Footage markers should be labeled on only one phase conductor at least every two feet.
- 5.4.3 The print legend should be ink jet non-contact printing, hot foil stamp printing, or SMUD approved equal.

## **5.5 CABLE ASSEMBLY**

- 5.5.1 The cables shall be assembled in accordance with UL 854 and either ICEA S-105-692 or ICEA S-81-570.

 ENG. SPEC. T003	REV. 9	<b>Residential Underground</b>	Page 15 of 19
---	-----------	--------------------------------	------------------

## **6 TECHNICAL DOCUMENTATION TO BE SUBMITTED WITH THE BID**

- 6.1** Cable manufacturer's compound number, source, and description of cable insulation(s) and/or jacket material shall be submitted.
- 6.2** An SDS shall be provided for each compound used in the manufacture of the cable.
- 6.3** A cross-sectional drawing or other sufficient detail of each cable being bid identifying the following:
  - 6.3.1 Cable conductor dimensions and description,
  - 6.3.2 Insulation and/or jacket dimensions and overall diameter for the phase conductor(s) and neutral conductor and
  - 6.3.3 Dimensions and tolerances of the overall diameter of the cable assembly.
- 6.4** Description of curing process and equipment manufacturer.
- 6.5** The shipping reel information for each cable being bid including:
  - 6.5.1 The reel flange diameter, the maximum overall width, and the drum diameter and
  - 6.5.2 The longest expected length of each cable type on the reel along with the maximum weight of each reel with the longest length.
- 6.6** Minimum bending radius of each cable being bid.
- 6.7** The maximum sidewall bearing pressure for each cable being bid.
- 6.8** The maximum pulling tension when pulled by jacket and by conductor for each cable being bid.

## **7 TESTING**

- 7.1** The cable shall meet all testing requirements in accordance with UL 854 for Type USE-2 applications.
- 7.2** The cable shall be tested in accordance with ICEA Standards S-105-692 or ICEA S-81-570, as applicable.
- 7.3** The test reports described under this specification shall be maintained by the manufacturer for a minimum of 5 years from the date of delivery.
- 7.4** A copy of any test report shall be made available to SMUD's Principal Distribution Design Engineer Standards upon request.

## **8 PACKAGING**

- 8.1** Cable shall be packaged and protected in accordance with NEMA Publication No. WC-26.
- 8.2** Cable shall be shipped on non-returnable reels built in accordance with NEMA Publication No. WC-26.



 ENG. SPEC. T003	REV. 9	<b>Residential Underground</b>	Page 16 of 19
---	-----------	--------------------------------	------------------

- 8.3 Cable reels shall be shipped in an upright position firmly secured to the pallet they are shipped on. Reels shall not be shipped with their flanges flat against the pallet they are shipped on.
- 8.4 Required shipping lengths will be defined in the bid document.

## **9 MATERIAL AND DESIGN CHANGES**

Following approval by SMUD of the specific design(s) and materials submitted to SMUD by the supplier, the supplier shall not make changes in such design(s) or materials without the prior written approval of SMUD. Any potential changes require submittal of information in accordance with section 6.

## **Appendix B: List of Material Suppliers**

The table below lists material suppliers with whom SMUD is familiar. It is not intended to be an exhaustive list of all possible suppliers in the area. There may be additional vendors that can provide the material required by this specification.

### **ARMORCAST PRODUCTS CO.**

13230 Saticoy Street.  
N. Hollywood, CA 91605  
(818) 982-3600  
Fax (818) 982-7742

### **AZCO SUPPLY, INC.**

2250 Stewart St. #9  
Stockton, Ca 95205-3244  
(209) 943-2452

### **CAPITAL WHOLESALE ELECTRIC**

1811 12<sup>th</sup> St  
Sacramento, CA 95811  
(916) 443-8051

### **CONSOLIDATED ELECTRICAL DISTRIBUTORS**

1800 24th Street  
Sacramento, CA 95816  
(916) 452-3111

### **ELECTROREP, INC.**

2015 Bridgeway, Suite 201  
Sausalito, CA 94965  
(415) 332-4100

### **ENERGY COMM**

P.O. Box 488  
Orinda, CA 94563  
(925) 254-3736

### **GRAYBAR ELECTRIC COMPANY**

P. O. Box G  
1211 Fee Drive  
Sacramento, CA 95815  
(916) 561-1900

### **HUBBELL POWER SYSTEMS**

210 N Allen  
Centralia, MO 65240  
(573) 682-5521

### **INDEPENDENT UTILITY SUPPLY**

4076 Channel Drive  
West Sacramento, CA 95691  
(916) 376-8400

### **JENSEN PRECAST**

5400 Raley Boulevard  
Sacramento, CA 95838  
(916) 991-8800  
(800) 843-9569

### **NEWBASIS**

2626 Kansas Ave.  
Riverside, CA  
(951) 787-0600

### **OLDCASTLE PRECAST, INC.**

3786 Valley Ave.  
Pleasanton, CA 94566-8183  
(925) 846-8183

### **REPLACON**

P.O. Box 186  
Sheridan, CA 95681  
(530) 633-2050

### **WESCO DISTRIBUTION. INC.**

1045 W National Drive, #19  
Sacramento, CA 95834  
(916) 928-1001

 ENG. SPEC. <b>T003</b>	<b>REV.</b> <b>9</b>	<b>Residential Underground</b>	<b>Page</b> <b>18 of 19</b>
--	-------------------------	--------------------------------	--------------------------------

### Appendix C: Design and Construction Drawings

The customer and/or their representatives or contractors shall adhere to the design and construction drawings listed in the table below, unless otherwise specified in writing by a SMUD inspector or designer. The Customer shall review all drawings. Any questions or comments shall be brought to Sacramento Municipal Utility District's (SMUD) attention for clarification or resolution.

Drawing Title	Page Number
REQUIRED MINIMUM CLEARANCES OF METER SOCKET FROM OBSTRUCTIONS	C-1
TYPICAL RESIDENTIAL UTILITY METER LOCATION	C-2
RESIDENTIAL <u>SUBDIVISION</u> SERVICE TRENCH AND CONDUIT DETAIL	C-3
RESIDENTIAL SERVICE FED FROM SMUD POLE	C-4
RESIDENTIAL SERVICE FED FROM SMUD POLE - DETAILS	C-5
ADVANCE PERMANENT RESIDENTIAL UNDERGROUND SERVICE	C-6
CLEARANCES FOR METER CABINET ENCLOSURES	C-7
CUSTOMER OWNED SERVICE PANEL FED FROM SMUD UNDERGROUND	C-8
METER ROOM ARRANGEMENTS FOR INDIVIDUALLY METERED APARTMENTS (SELF-CONTAINED SOCKET TYPE METERS)	C-9
OVERHEAD AND UNDERGROUND SERVICE CLEARANCES FROM SWIMMING POOLS	C-10
DIAGRAMS OF CONNECTIONS, METER SOCKETS FOR SELF-CONTAINED METERS 0-200 AMP SINGLE PHASE SOCKETS	C-11
RESIDENTIAL METER REQUIREMENTS	C-12
SMUD ELECTRICAL SERVICE REQUIREMENTS FOR CUSTOMER RUN SERVICE TO RESIDENTIAL SUBDIVISION, SINGLE FAMILY THROUGH SIXPLEX DWELLINGS	C-13
CUSTOMER INSTALLED SERVICE WHERE SMUD SECONDARY BOX IS PRESENT AND FOUNDATION HOUSE SERVICE	C-14
DETAIL TYPICAL CONDUIT TERMINATION	C-15

 <b>SMUD</b> ENG. SPEC. <b>T003</b>	<b>REV.</b> <b>9</b>	<b>Residential Underground</b>	<b>Page</b> <b>19 of 19</b>
---	-------------------------	--------------------------------	--------------------------------

Drawing Title	Page Number
SERVICE PANEL: UPGRADING, REPLACING, RELOCATING ELECTRIC FACILITIES FOR SINGLE-PHASE 120V SERVICE	C-16
INSTALLATION FOR 17"X30", 24"X36", & 30"X48" FULL TRAFFIC BOXES	C-17
CONDUIT DRAIN FOR ELEVATED SERVICE BOX	C-18
SINGLE PHASE TRANSFORMER PAD INSTALLATION 44"X51"	C-19

#### Appendix D: EUSERC Drawings

Drawing Title	Page Number
TYPICAL RESIDENTIAL MULTIPLE METERING INSTALLATION	D-1
SAFETY SOCKET BOX WITH FACTORY INSTALLED TEST BYPASS DEVICES, 100 AMPERES MAXIMUM	D-2
SAFETY SOCKET BOX WITH FACTORY INSTALLED TEST BYPASS DEVICES, 200 AMPERES MAXIMUM	D-3
TEST BYPASS BLOCKS FOR SAFETY SOCKET, 0-200 AMPERES	D-4
400 AMPERES (CLASS 320) RESIDENTIAL METER PANEL WITH MANUAL TEST BYPASS STUDS 120/240 VOLT, SINGLE PHASE 3 WIRE	D-5
METER PANEL WITHOUT BYPASS FACILITY, RESIDENTIAL UNDERGROUND SERVICE 400 AMPERES (CLASS 320), 120/240 VOLTS, 1PHASE 3 WIRE	D-6

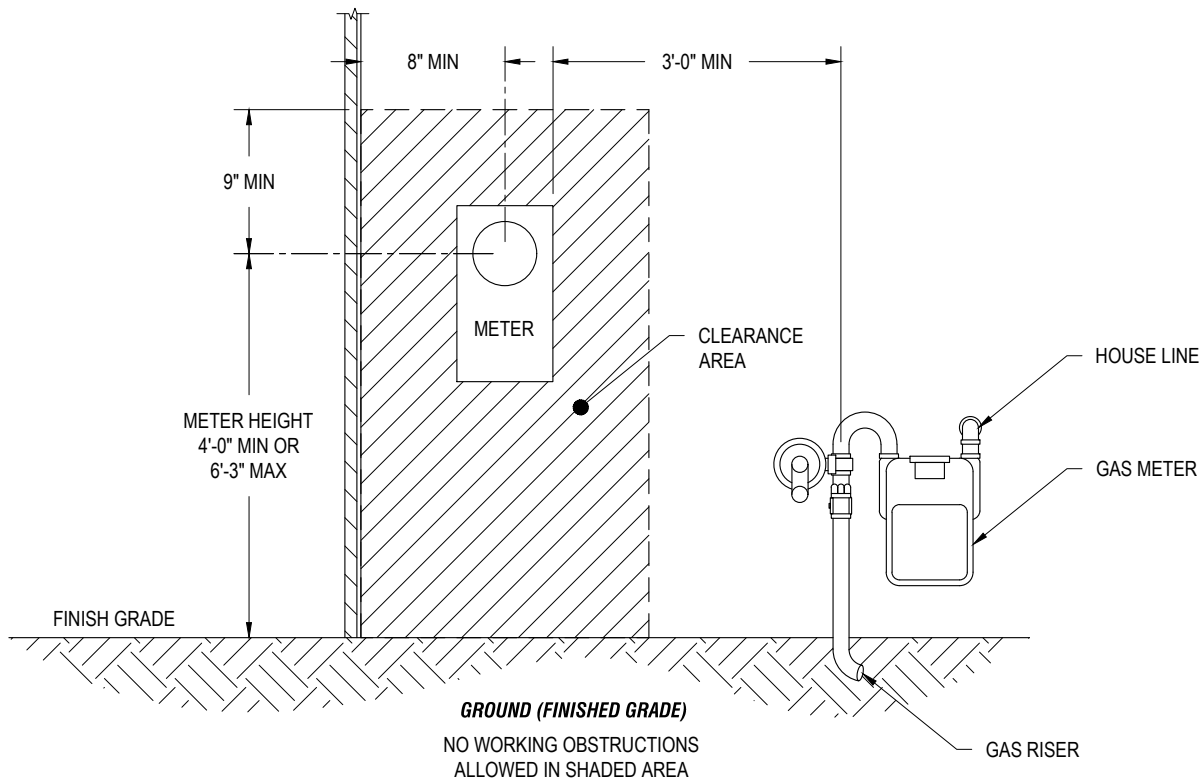
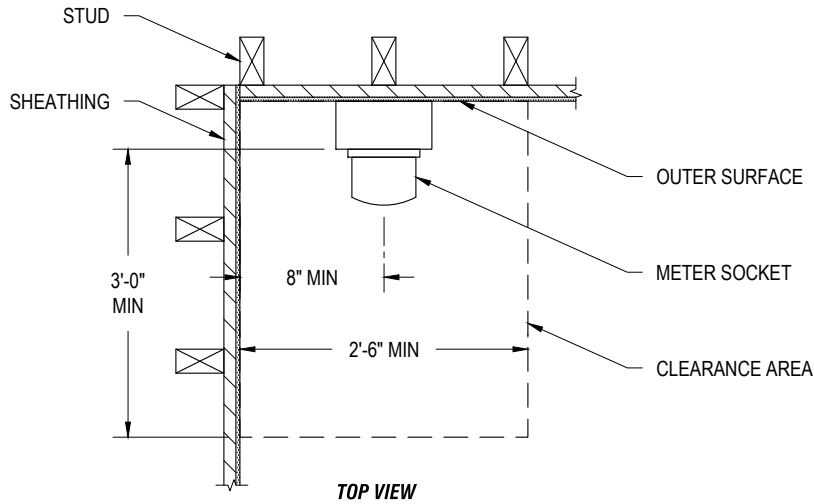

----- INDICATES BOUNDARY OF AREA WHICH MUST BE KEPT CLEAR OF OBSTRUCTIONS.

**NOTES:**

- A. MAINTAIN A CLEARANCE AREA AROUND THE SOCKET AS SHOWN IN THE ILLUSTRATIONS.
- B. THERE MUST BE AN 8" MIN HORIZONTAL & A 9" MIN VERTICAL (ABOVE) CLEARANCE BETWEEN THE CENTER OF THE METER SOCKET & ANY OBSTRUCTION (NO OBSTRUCTIONS IN THE CLEARANCE AREA SEE DRAWING ABOVE).
- C. A LEVEL STANDING SPACE AT LEAST 3'-0" L X 2'-6" W SHALL BE MAINTAINED IN FRONT OF THE METER SOCKET TO ALLOW FOR INSTALLATION, TESTING & READING (SEE SEC. 3-3.1.1.3 PAGE 4).
- D. METERS SHALL BE LOCATED SO THAT THEY WILL NOT BE DAMAGED BY A SWINGING WINDOW, DOOR, OR GATE.
- E. THE SURFACE OF THE WALL ON EITHER SIDE OF A WINDOW, DOOR, OR GATE FOR THE DISTANCE EQUAL TO THE WIDTH OF THE WINDOW, DOOR, OR GATE, IS UNACCEPTABLE AS A METER SPOT, UNLESS A SUITABLE STOP SHALL BE INSTALLED.



ESR: T003

ESR PG. NO.: C-1

REV. DATE: OCTOBER 2024  
REV. NO.: 6

**REQUIRED MINIMUM CLEARANCES OF METER SOCKET FROM OBSTRUCTIONS**

STANDARD NO.:  
**ZM2.0**

**"A" - RIGHT HAND GARAGE**

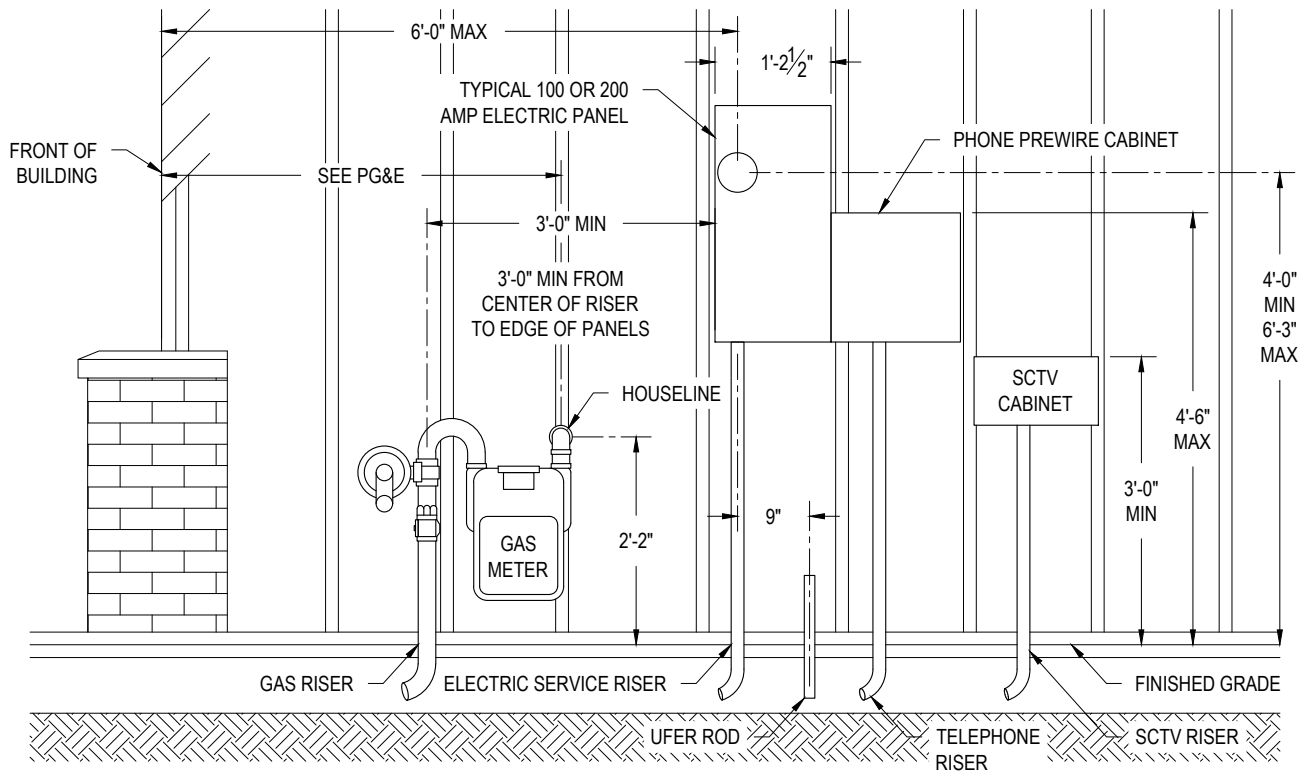

**"B" - LEFT HAND GARAGE**

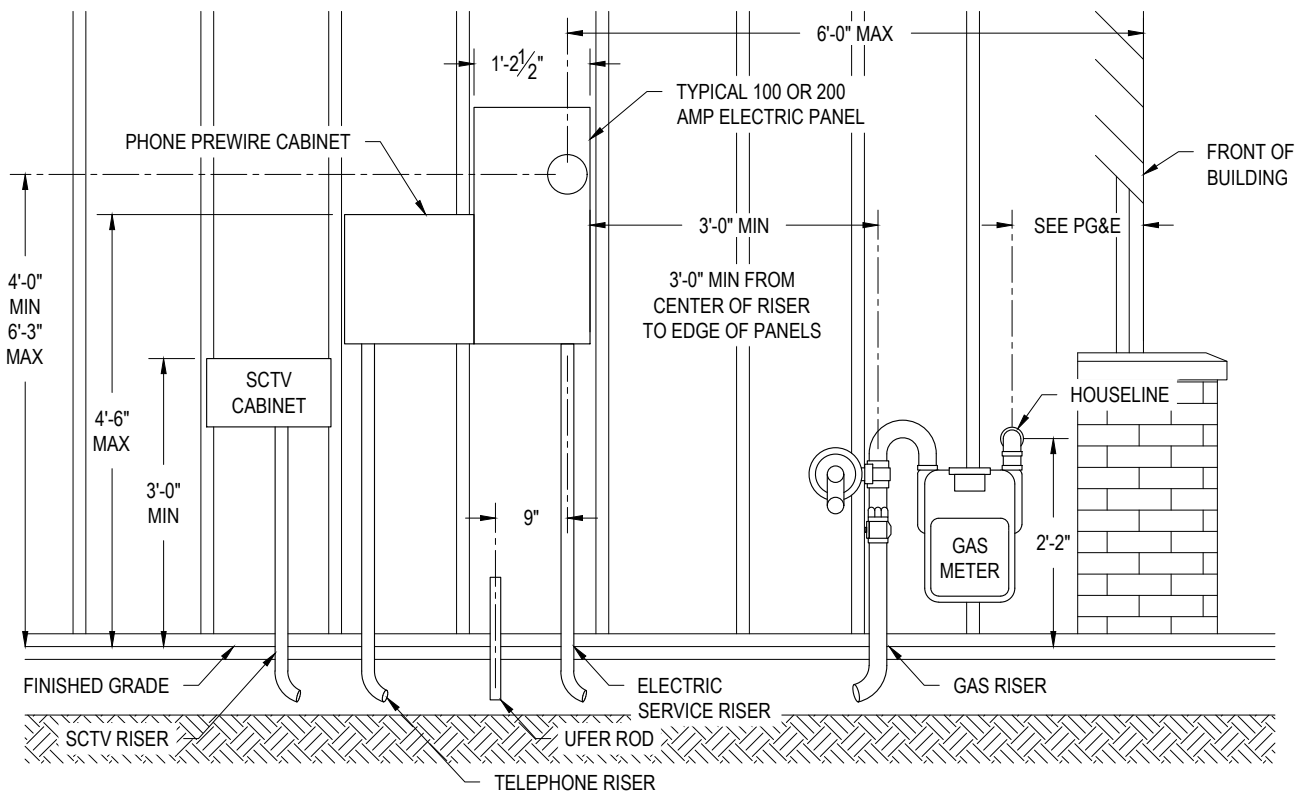

**NOTES:**

A. CONTACT GAS, TELEPHONE AND CABLE TV SERVICE PROVIDERS FOR THEIR SPECIFIC REQUIREMENTS.



ESR: T003

ESR PG. NO.: C-2

REV. DATE: OCTOBER 2024  
REV. NO.: 7

TYPICAL RESIDENTIAL UTILITY METER LOCATION

STANDARD NO.:

---

PAGE 1 OF 1

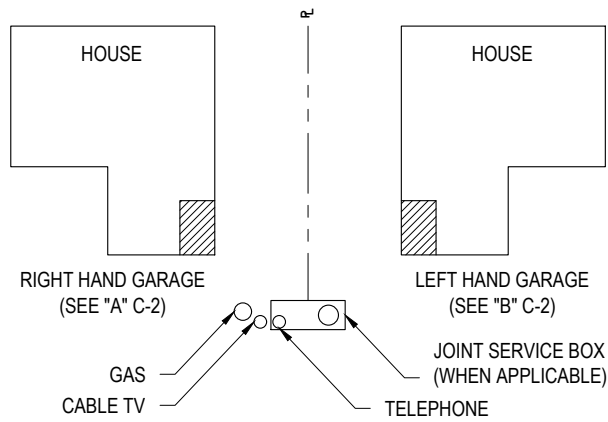

**PLAN VIEW  
SERVICE TERMINATION POINTS**

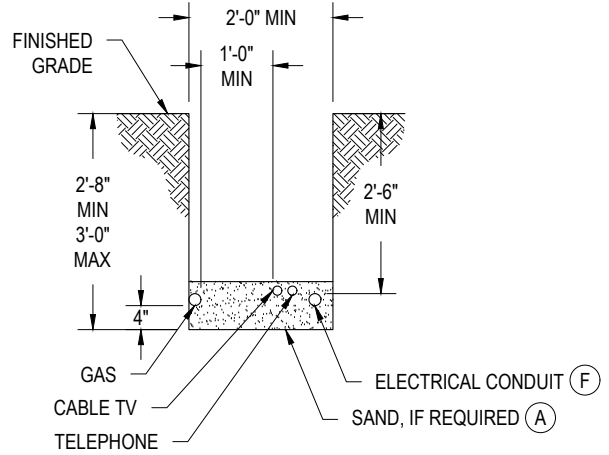

**TYPICAL JOINT  
SERVICE TRENCH DETAIL**

**NOTES:**

- A. WHEN DIGGING IN ANY AREA THAT CONTAINS ROCKS OR BACKFILL MATERIAL LARGER THAN 3", SAND BACKFILL WILL BE REQUIRED 1'-0" OVER THE TOP MOST UTILITY.
- B. CONTACT PG&E, TELEPHONE COMPANY, AND CABLE T.V. FOR THEIR SPECIFIC REQUIREMENTS.
- C. THE DEVELOPER MUST PROVIDE SAND BACKFILL AT THE HOUSE PER DETAIL IN ORDER TO MEET CITY/COUNTY CONSTRUCTION REQUIREMENTS. SAND BACKFILL IS REQUIRED TO MEET COMPACTION REQUIREMENTS NEXT TO AND UNDER THE HOUSE FOUNDATION.
- D. THE GAS RISER MUST HAVE 3'-0" HORIZONTAL CLEARANCE FROM THE ELECTRIC SERVICE PANEL.
- E. THE ELECTRIC METER(S) SHALL BE LOCATED WITHIN 6'-0" OF THE CORNER OF THE BUILDING CLOSEST TO THE SMUD SERVICE POINT. SEE PAGE C-2 FOR RESIDENTIAL UTILITY METER LOCATIONS. CONTACT SMUD LINE DESIGN DEPARTMENT IF A PHYSICAL OBSTRUCTION MIGHT INTERFERE WITH THE PREFERRED LOCATION.
- F. ELECTRIC SERVICE CONDUIT SHALL TERMINATE IN THE UTILITY SERVICE BOX. ELECTRIC CONDUIT SHALL BE 2" MINIMUM. THE ELECTRICAL CONDUIT SHALL HAVE A MINIMUM COVER OF 2'-6" AT OR NEAR THE UTILITY METER LOCATION.
- G. 6" MINIMUM VERTICAL CLEARANCE MUST BE MAINTAINED AT CONDUIT CROSSING.

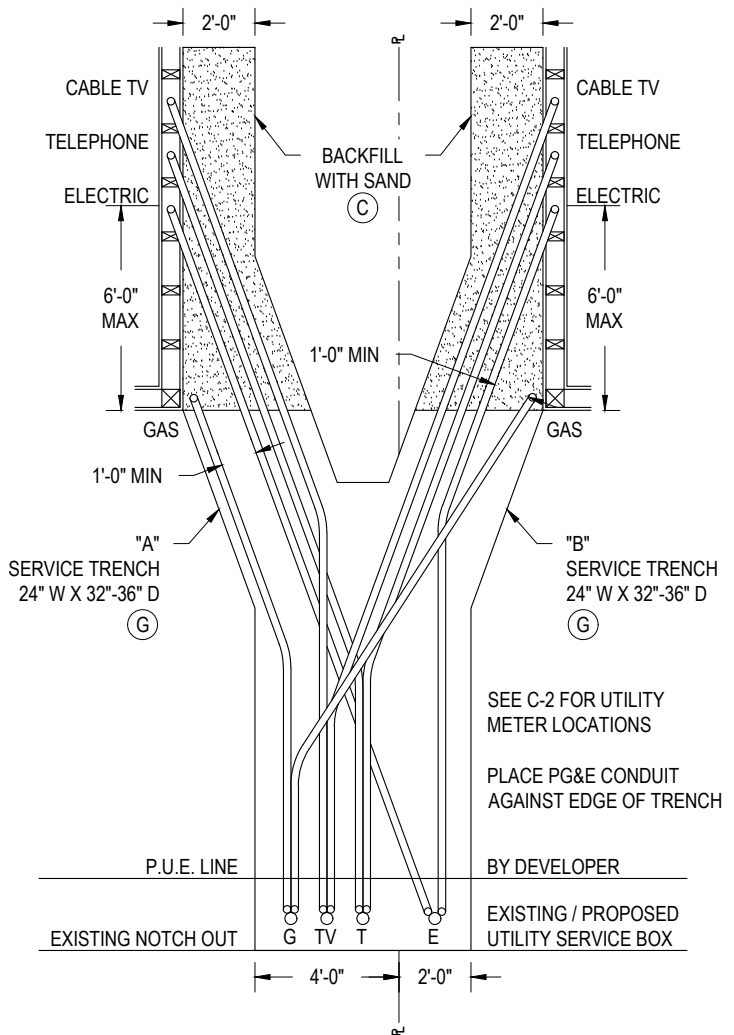

**DETAIL - 1  
TYPICAL SERVICE CONDUIT RUNS DETAIL**



ESR: T003

ESR PG. NO.: C-3

REV. DATE: OCTOBER 2024  
REV. NO.: 7

**RESIDENTIAL SUBDIVISION SERVICE  
TRENCH AND CONDUIT DETAIL**

STANDARD NO.:

---

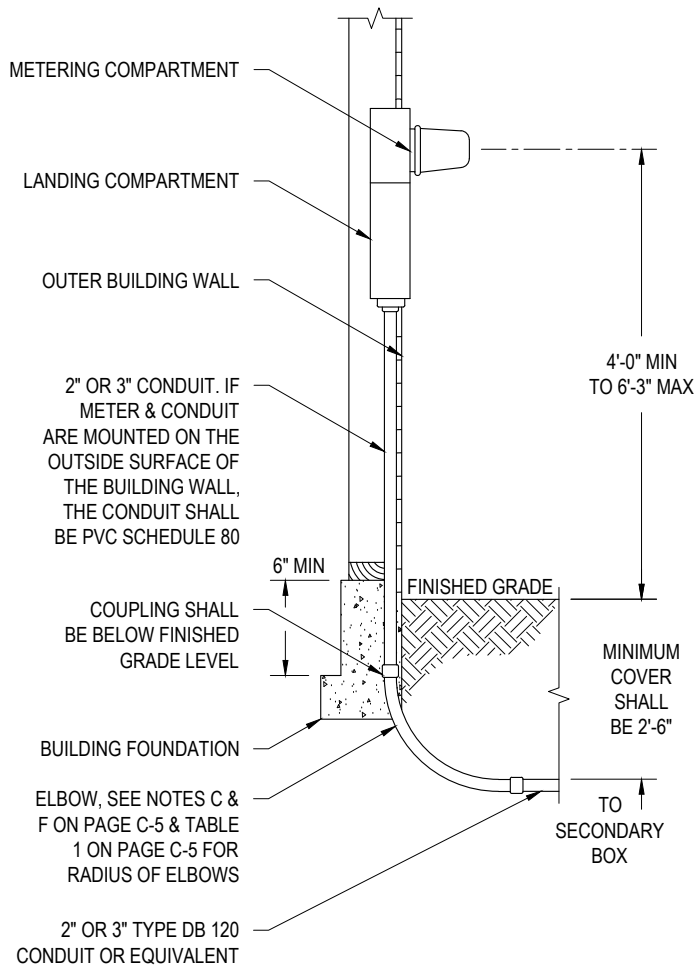

**METER DETAIL**

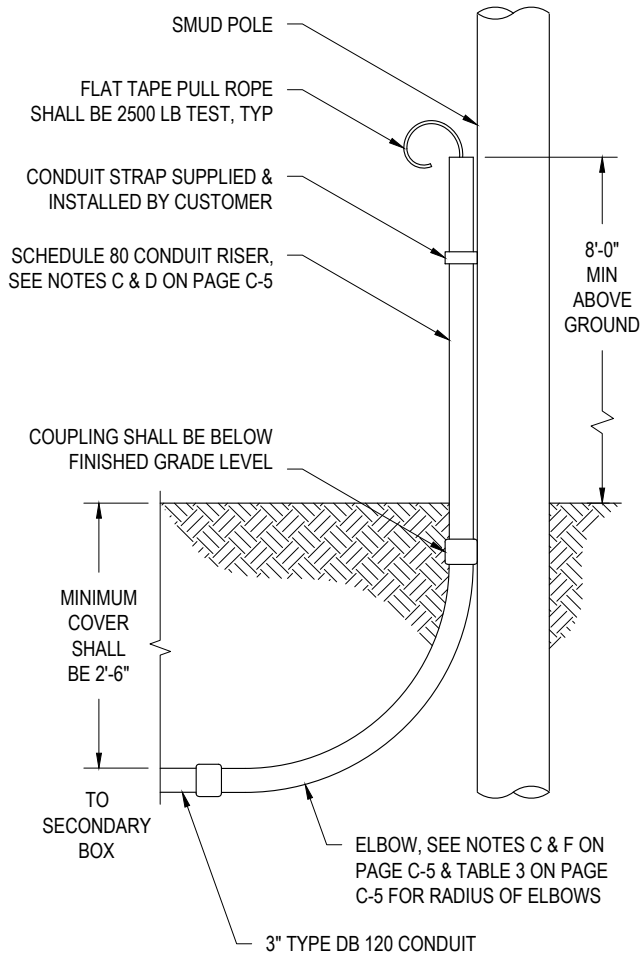

**SECONDARY RISER DETAIL**

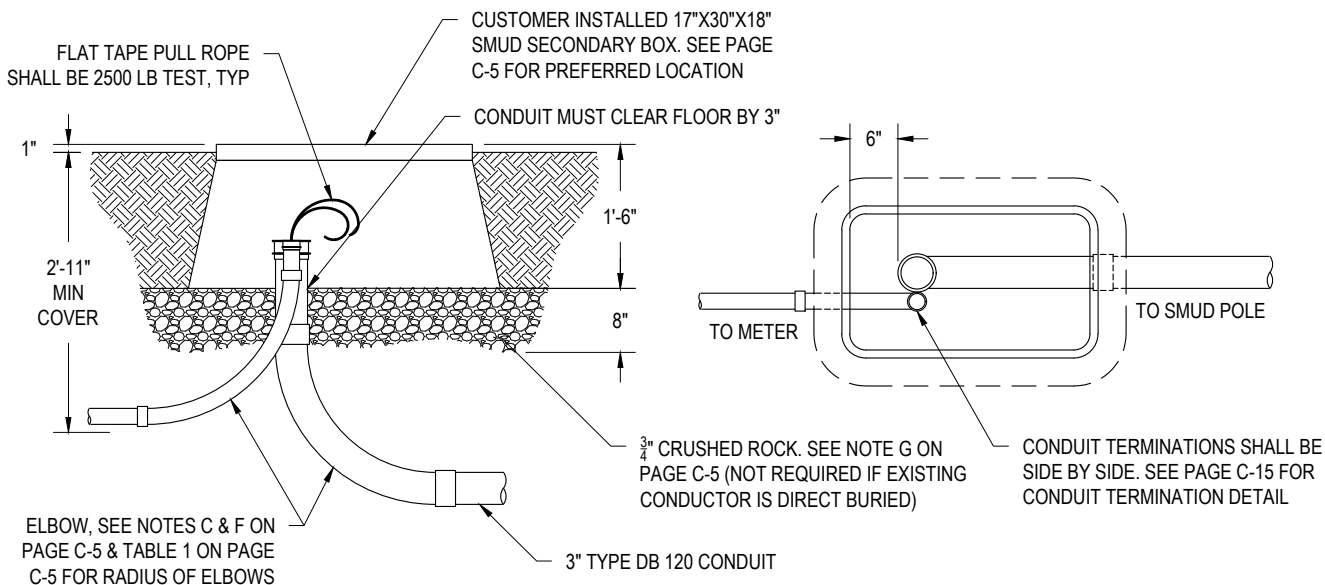

**SECONDARY BOX DETAIL**



ESR: T003

ESR PG. NO.: C-4

REV. DATE: OCTOBER 2024  
REV. NO.: 8

RESIDENTIAL SERVICE FEED FROM SMUD POLE

STANDARD NO.:

---



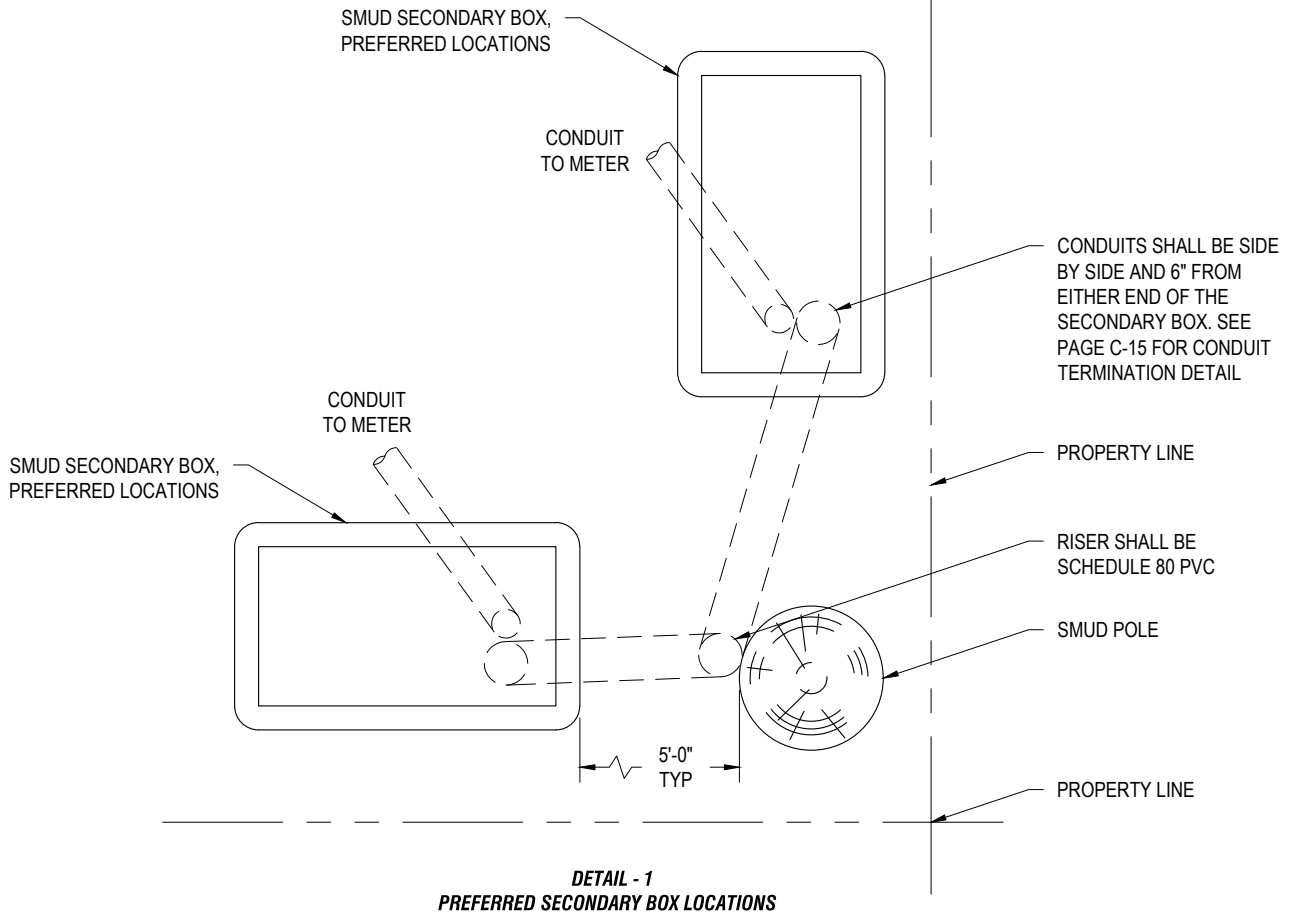

**TABLE - 1**

MINIMUM ELBOW RADIUS FOR ALL SERVICE CONDUIT ELBOWS (11¼°, 22½°, 45° & 90°)	
CONDUIT SIZE	RADIUS
2" - 3"	1'-6"
4" (CONSULT DESIGNER)	2'-6"

**TABLE - 2**  
**CONDUIT REQUIREMENTS**

MAIN SIZE	0' - 100'	101' - 300'
0 - 200A	2"	3"
201 - 400A	3"	3" OR 4" (CONSULT DESIGNER)
CONTACT SMUD DISTRIBUTION LINE DESIGN DEPARTMENT FOR ANY COMBINATION OF METERS OVER 400 AMPS		

**TABLE - 3**

MINIMUM ELBOW RADIUS FOR ALL SECONDARY CONDUIT ELBOWS (PER U1N2C2)	
3"	2'-6"

**NOTES:**

- THE CUSTOMER SHALL FURNISH AND INSTALL ALL MATERIAL IN ANY SERVICE INSTALLATION, EXCEPT THE SERVICE CABLE AND THE METER UNLESS OTHERWISE DIRECTED BY SMUD'S LINE DESIGN DEPARTMENT.
- THE CUSTOMER SERVICE ENTRANCE INSTALLATION MUST INCLUDE A SEPARATE LANDING COMPARTMENT WHICH WILL PROVIDE THE APPROPRIATE LANDING LUGS, BARRIERS, AND SEALABLE COVER.
- ELECTRICAL CONDUIT EXPOSED ABOVE GROUND SHALL BE SCHEDULE 80 PVC OR EQUIVALENT. ALL OF THE ELBOWS SHALL BE SCHEDULE 40 PVC OR EQUIVALENT. ELECTRICAL CONDUIT WITHIN BUILDING WALLS SHALL BE SCHEDULE 40 PVC OR EQUIVALENT AND SHALL BE A CONTINUOUS RUN.
- THE CUSTOMER SHALL INSTALL AND ATTACH ONE 10'-0" SECTION OF SCHEDULE 80 PVC CONDUIT ON THE SMUD POLE IN THE QUADRANT DESIGNATED BY THE SMUD'S LINE DESIGN DEPARTMENT OR SMUD INSPECTOR. SEE TABLES 1 & 3 FOR CONDUIT RADIUS. CONDUIT SIZE IS DEPENDENT ON CONDUCTOR SIZE.
- SMUD SHALL BE CONTACTED A MINIMUM OF FIVE (5) WORKING DAYS IN ADVANCE OF INSTALLATION FOR A PRE-CONSTRUCTION MEETING. IF THE TRENCH IS BACK FILLED PRIOR TO INSPECTION, THE CUSTOMER MAY BE REQUIRED TO POTHOLE THE TRENCH FOR INSPECTION PURPOSES.
- THE MAXIMUM NUMBER OF ELBOWS FROM THE CUSTOMER LANDING COMPARTMENT TO THE SECONDARY BOX IS THREE. (3-90'S OR 270°) LIKEWISE, THE MAXIMUM NUMBER OF ELBOWS FROM THE SMUD POLE TO THE SECONDARY BOX IS THREE. (3-90'S OR 270°)
- THE SECONDARY BOX SHALL BE PLACED LEVEL ON AN 8" CONSOLIDATED LAYER OF ¾" CRUSHED ROCK.
- IF THE 5'-0" DISTANCE BETWEEN THE SECONDARY BOX AND THE SMUD POLE IS NOT OBTAINABLE AND/OR IF THE SECONDARY BOX CANNOT BE INSTALLED IN THE PREFERRED LOCATION (SEE DETAIL "A") CONTACT SMUD'S LINE DESIGN DEPARTMENT OR SMUD INSPECTOR.
- WHEN DIGGING IN ANY AREA THAT CONTAINS ROCKS OR BACKFILL MATERIAL LARGER THAN 3", SAND BACKFILL SHALL BE REQUIRED 1'-0" OVER THE TOP MOST UTILITY.



ESR: T003

ESR PG. NO.: C-5

REV. DATE: OCTOBER 2024  
REV. NO.: 8

RESIDENTIAL SERVICE FED FROM POLE - DETAILS

STANDARD NO.:

---

PAGE 1 OF 1

4'-0" MIN TO  
6'-3" MAX

1/4" X 1/2" STRAP IRON

STEEL LEG SHALL  
EXTEND A MIN OF  
8" INTO FOOTING

FOUNDATION  
WALL

1/4"

MINIMUM OF (4) 1/4" BOLTS  
(2 ON EACH SIDE)

SEE CONDUIT  
REQUIREMENTS ON  
PAGES C-4 AND C-5

TO APPROVED  
GROUND ELECTRODE

1/4" X 1/2" STRAP IRON

FOUNDATION MUST BE  
POURED BEFORE SERVICE  
CAN BE CONNECTED

FINISHED GRADE

**NOTES:**

- A. ADVANCE PERMANENT RESIDENTIAL SERVICES WILL ONLY BE CONSIDERED FOR CONNECTION WHEN THE REQUIREMENTS OF THIS DRAWING ARE MET.

2'-6"  
MIN  
COVER



ESR: T003

ESR PG. NO.: C-6

REV. DATE: OCTOBER 2024  
REV. NO.: 7

ADVANCE PERMANENT  
RESIDENTIAL UNDERGROUND SERVICE

STANDARD NO.:

---

PAGE 1 OF 1

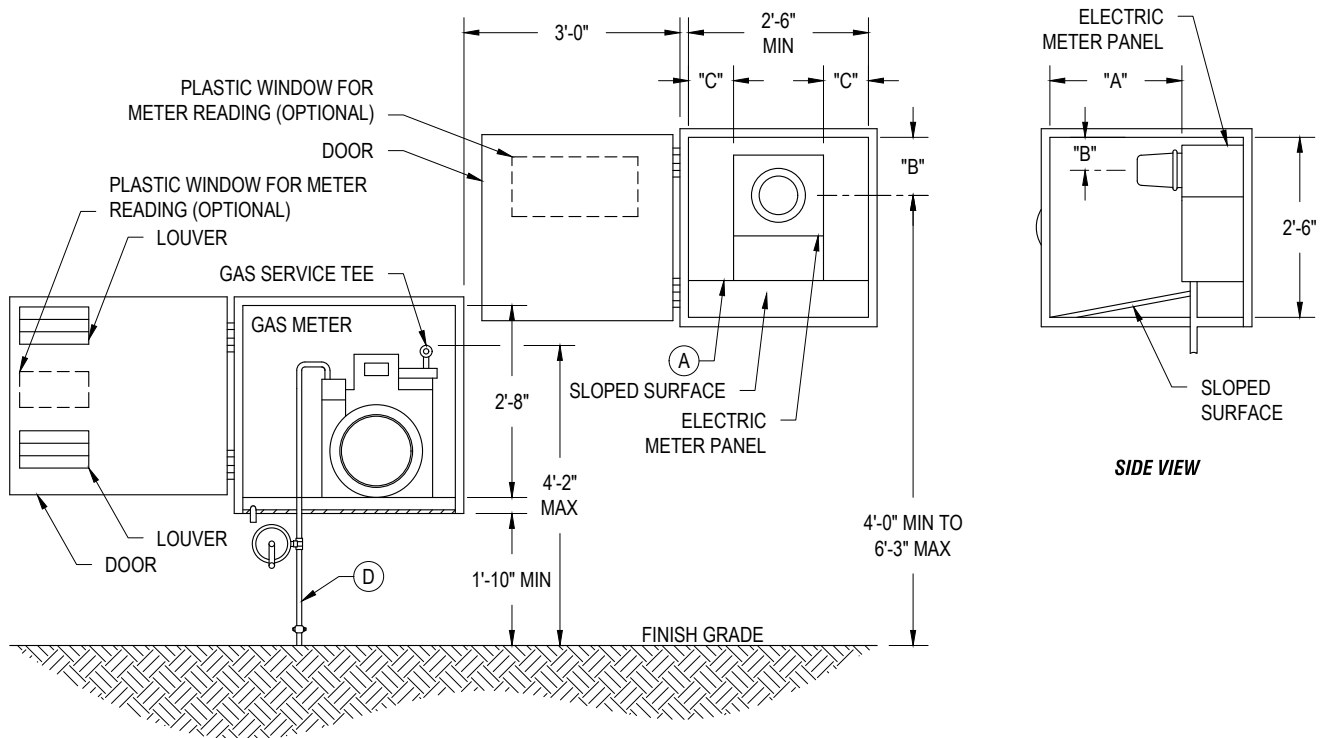

FRONT VIEW

METER DIMENSIONS

DIMENSION	TYPE OF METER	MINIMUM	MAXIMUM
"A"	RESIDENTIAL SINGLE-PHASE OR APARTMENT METERS	7"	1'-3"
	COMMERCIAL SINGLE-PHASE OR APARTMENT "HOUSE" METERS	9"	1'-3"
	COMMERCIAL POLYPHASE	11"	1'-3"
"B"	RESIDENTIAL OR COMMERCIAL SINGLE-PHASE METERS	7"	NONE
	COMMERCIAL POLYPHASE	9"	NONE
"C"	RESIDENTIAL OR COMMERCIAL SINGLE-PHASE	2 $\frac{1}{2}$ "	NONE
	COMMERCIAL POLYPHASE (A)		

\* DIMENSION "A" APPLIES ONLY TO THAT PORTION OF THE CABINET ENCLOSING DOOR IN FRONT OF THE METER

NOTES:

- A. METER SOCKETS, HAVING JAWS THAT MUST BE TIGHTENED WITH A WRENCH, SHALL BE INSTALLED WITH A MINIMUM OF 10" CLEAR SPACE ON EACH SIDE TO PERMIT USE OF THE WRENCH.
- B. CARE SHOULD BE EXERCISED TO DESIGN THE CABINET SUCH THAT NEITHER THE ROOF NOR DOOR SUPPORTS WILL INTERFERE WITH INSTALLATION OF THE METER. WITH THE CABINET DOOR OPEN, A LEVEL STANDING SPACE OF AT LEAST 3'-0" L X 2'-6" W DIRECTLY IN FRONT OF THE SOCKET IS REQUIRED TO INSERT THE METER INTO THE SOCKET.
- C. WHEN THE CABINET DOOR IS LOCKABLE, A DOUBLE LOCK ARRANGEMENT IS REQUIRED.
- D. GAS RISER CANNOT BE LOCATED UNDER ANY PORTION OF ELECTRIC METER PANEL.
- E. CONTACT PG&E FOR ADDITIONAL REQUIREMENTS AND CLEARANCES FOR THE GAS CABINET.



ESR: T003

ESR PG. NO.: C-7

REV. DATE: OCTOBER 2024  
REV. NO.: 8

CLEARANCES FOR METER CABINET ENCLOSURES

STANDARD NO.:

---

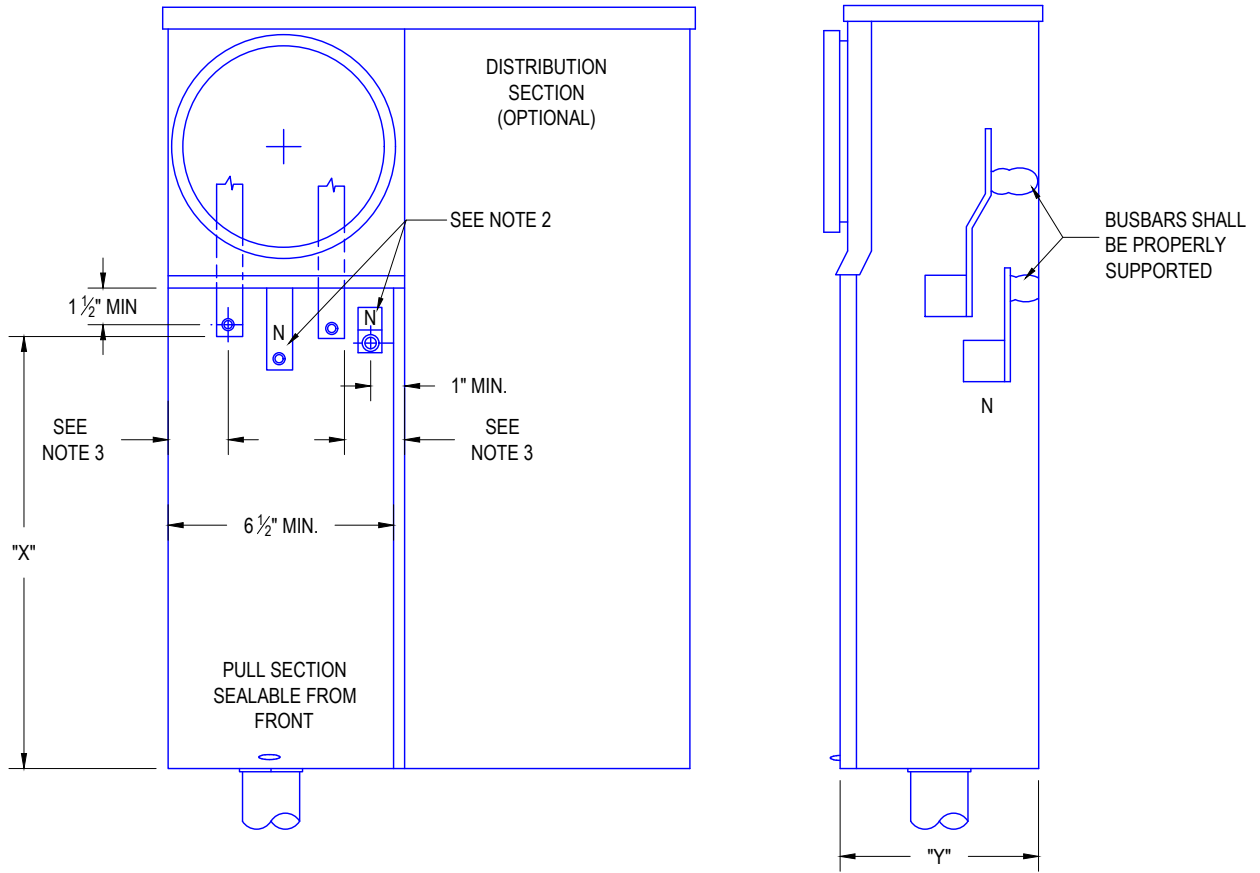

MAXIMUM CAPACITY	"X" MIN. DIM.	"Y" MIN. DIM.
125 AMP.	8"	4"
225 AMP.	11"	5"
400 AMP.	VERIFY WITH SMUD'S METERING DEPARTMENT	

NOTES:

- A. TERMINALS FOR SERVICE CONDUCTORS SHALL BE ALUMINUM BODIED RANGE TAKING LUGS WITH A MINIMUM RANGE OF NO. 6 THROUGH 2/0 AWG FOR THE 125 AMPERE UNIT AND 1/0 AWG THROUGH 250 MCM FOR THE 225 AMPERE UNIT.
- B. THE MINIMUM DIMENSION FROM THE NEUTRAL TERMINAL TO THE ENCLOSURE BOTTOM SHALL BE 6" FOR THE 125 AMPERE UNIT AND 8 1/2" FOR THE 225 AMPERE UNIT. IF THE NEUTRAL TERMINAL IS INSULATED FROM THE ENCLOSURE, PROVIDE A BONDING SCREW OR JUMPER.
- C. A MINIMUM RADIAL CLEARANCE OF 1 1/2" SHALL BE PROVIDED BETWEEN THE HOT BUS TERMINALS AND THE GROUND OR NEUTRAL SURFACES.
- D. RESIDENTIAL SELF-CONTAINED METER SOCKETS SHALL BE UL APPROVED AND SHALL HAVE A MAXIMUM CURRENT RATING EQUAL TO OR GREATER THAN THE CURRENT RATING OF THE ASSOCIATED LOAD SERVICE EQUIPMENT.



ESR: T003

ESR PG. NO.: C-8

REV. DATE: OCTOBER 2024  
REV. NO.: 7

CUSTOMER OWNED  
SERVICE PANEL FED  
FROM SMUD UNDERGROUND

STANDARD NO.:

---

PAGE 1 OF 1

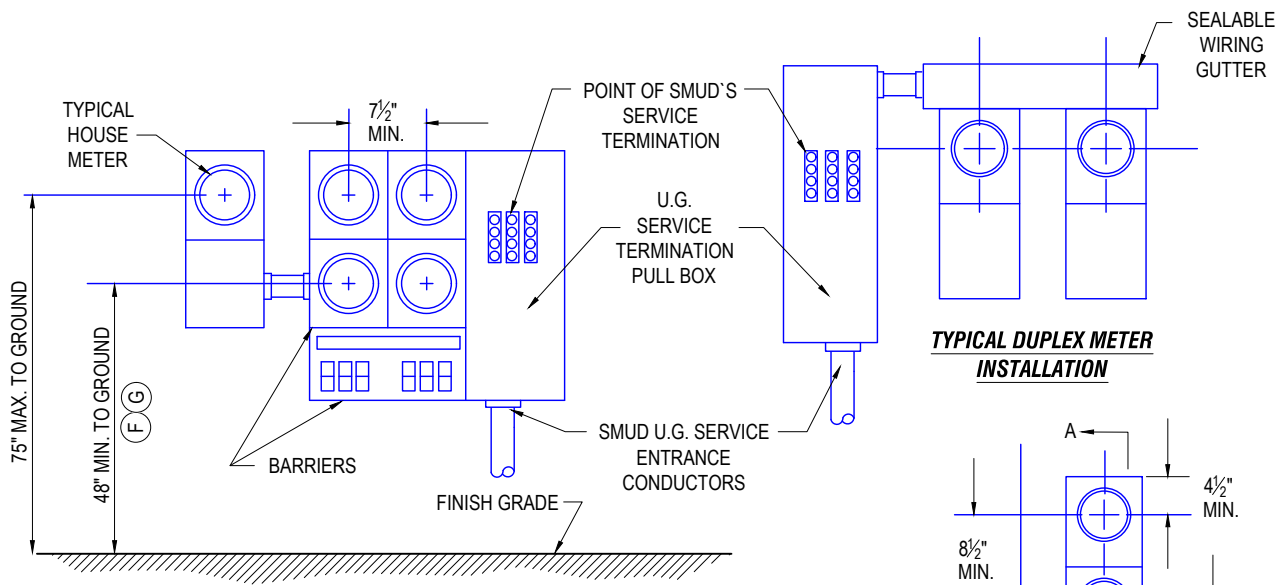

**FIGURE 1**  
TYPICAL MULTI-METER INSTALLATION 6 METERS OR LESS  
(INCLUDES HOUSE METER)

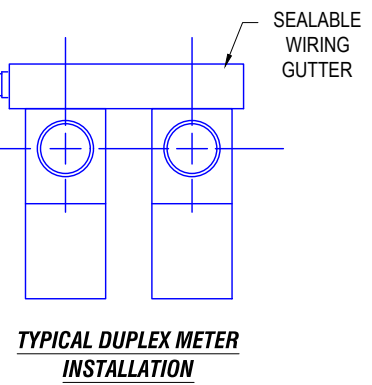

**TYPICAL DUPLEX METER  
INSTALLATION**

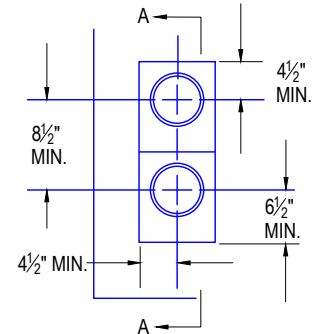

**METER SOCKET SPACING DETAIL**

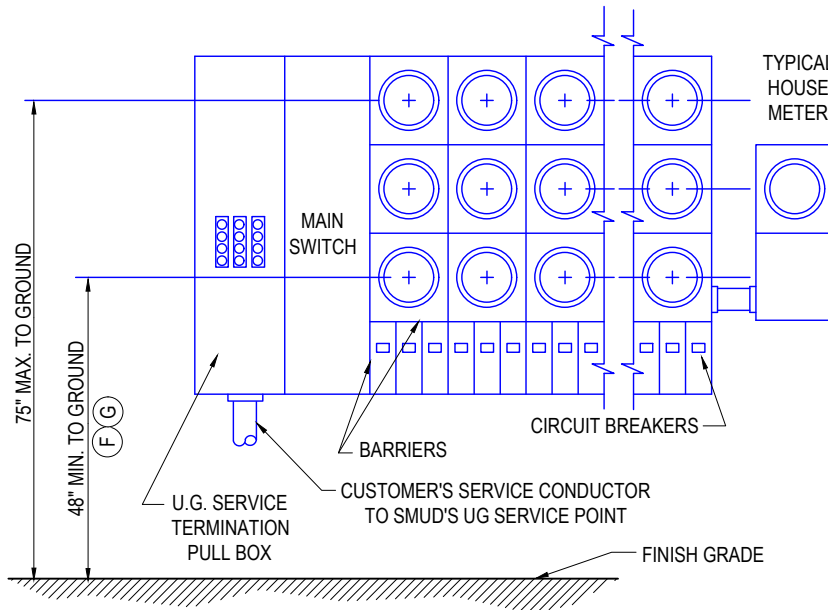

**FIGURE 2**  
TYPICAL MULTI-METER INSTALLATION 7  
METERS OR MORE

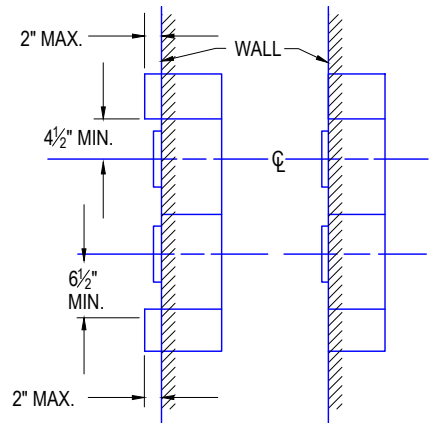

**SECTION A-A**  
RECESSED METER  
SOCKETS

**SECTION A-A**  
FLUSH METER  
SOCKETS

**NOTES:**

- A. TEST BYPASS DEVICES ARE NOT TO BE INSTALLED ON INDIVIDUAL APARTMENT METERS.
- B. FOR TEST BYPASS REQUIREMENTS ON APARTMENT "HOUSE" METERS, SEE PAGES D-2 THROUGH D-4.
- C. THE PANEL DESIGN SHALL PERMIT CONVENIENT REPLACEMENT OF ANY INDIVIDUAL METER SOCKET JAW ASSEMBLY.
- D. METER PANELS SHALL BE SEALABLE.
- E. BEFORE USING THESE ARRANGEMENTS ON 3-PHASE, 4-WIRE SERVICES, CONSULT SMUD'S LINE DESIGN DEPARTMENT.
- (F) FOR OUTDOOR INSTALLATIONS, THE MAXIMUM METER HEIGHT IS 75" & THE MINIMUM IS 48". WHEN VERTICALLY STACKED, THE MINIMUM METER HEIGHT MAY BE REDUCED TO 42".
- (G) FOR INSTALLATIONS INSIDE A DOUBLE LOCKED CABINET OR METER ROOM THE MINIMUM METER HEIGHT MAY BE REDUCED TO 36".

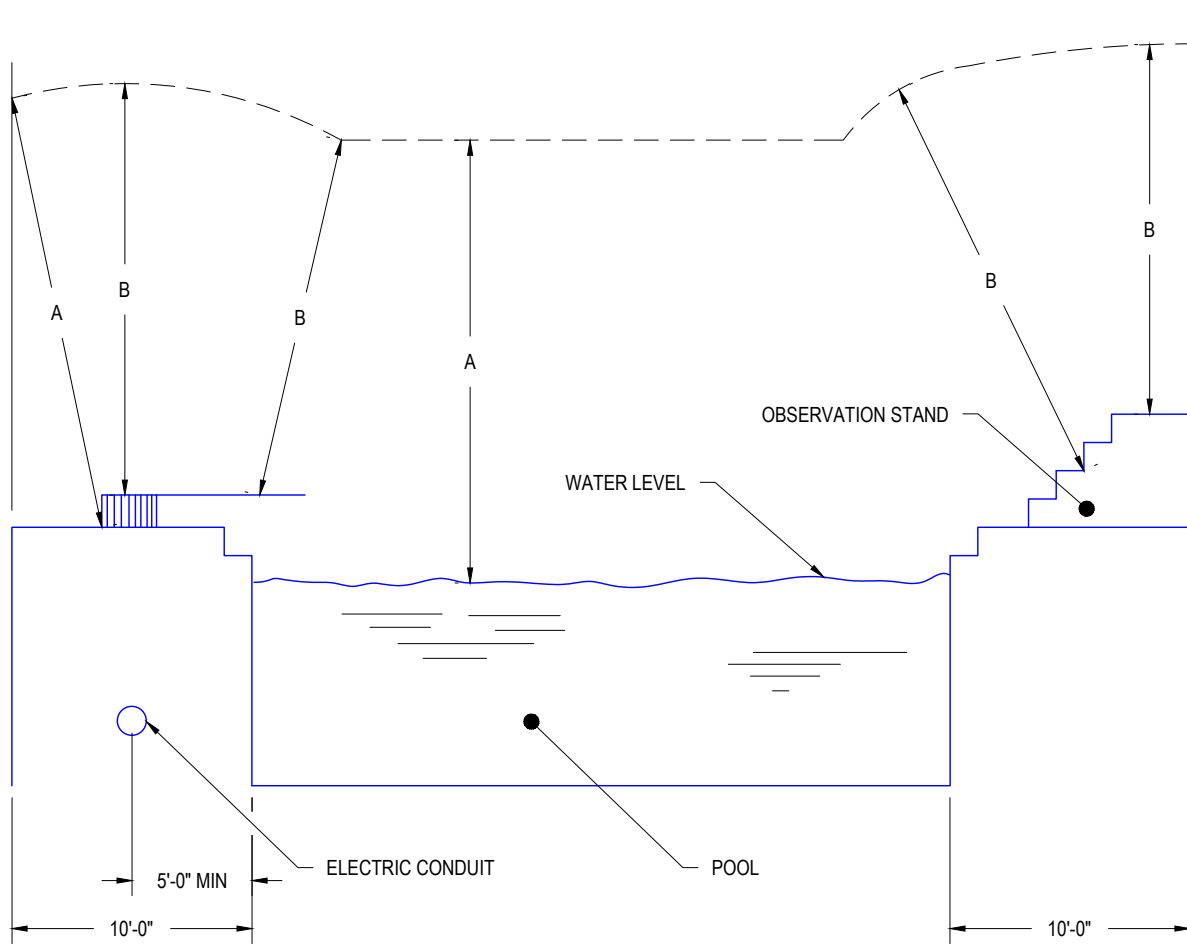

**CLEARANCES**

	INSULATED SUPPLY OR SERVICE DROP CABLES, 0-750 VOLTS TO GROUND, SUPPORTED ON AND CABLED TOGETHER WITH AN EFFECTIVELY GROUNDED BARE MESSENGER	ALL OTHER CONDUCTORS	
		VOLTAGE TO GROUND	
		0-15 KV	15-50 KV
A. CLEARANCE IN ANY DIRECTION TO THE WATER LEVEL, EDGE OF WATER SURFACE, BASE OF DIVING PLATFORM OR PERMANENTLY-ANCHORED RAFT.	22'-6"	25'-0"	27'-0"
B. CLEARANCE IN ANY DIRECTION TO THE OBSERVATION STAND, DIVING PLATFORM OR TOWER.	14'-6"	17'-0"	18'-0"

**NOTES:**

A. CLEARANCES PER LATEST NEC/GENERAL ORDER 95.



**ESR: T003**

**ESR PG. NO.: C-10**

REV. DATE: OCTOBER 2024  
REV. NO.: 7

**OVERHEAD AND UNDERGROUND SERVICE CLEARANCES FROM SWIMMING POOLS**

STANDARD NO.:

---

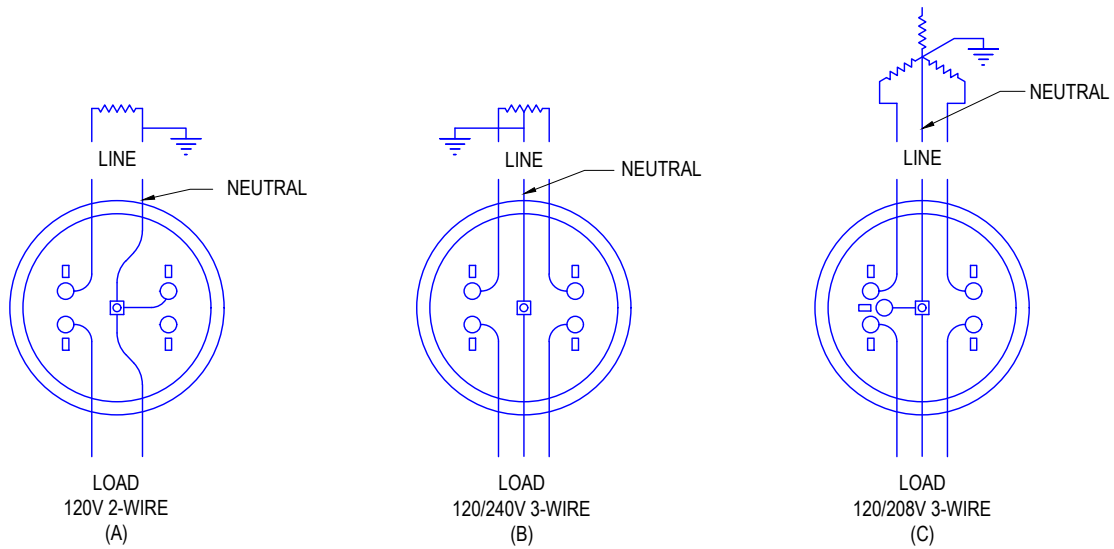

NOTES:

- A. SOCKETS FOR RESIDENTIAL INSTALLATIONS SHALL NOT BE EQUIPPED WITH TEST BYPASS DEVICES.
- B. LINE CONDUCTORS SHALL ALWAYS BE CONNECTED TO THE TOP TERMINALS OF THE SOCKET, AND LOAD CONDUCTOR CONNECTED TO THE BOTTOM TERMINALS OF THE SOCKET.
- C. NEUTRAL TAPS SHALL BE CONNECTED TO THE SERVICE NEUTRAL CONDUCTOR AND LOCATED BEHIND SEALED PANELS. WIRE NUTS ARE NOT PERMITTED.
- D. RESIDENTIAL, SELF-CONTAINED METER SOCKETS SHALL BE UL APPROVED AND SHALL HAVE A MAXIMUM CURRENT RATING EQUAL TO OR GREATER THAN THE CURRENT RATING OF THE ASSOCIATED LOAD SERVICE EQUIPMENT.
- E. METER SOCKETS WITH EXTRUDED OR CAST ALUMINUM JAWS ARE NOT ACCEPTABLE AND WILL NOT BE CONNECTED.
- F. NEUTRAL LINE WIRE (WHITE) SHALL BE CONTINUOUS WITHOUT A SPLICE FROM THE SERVICE HEAD THROUGH THE BONDING LUG TO THE NEUTRAL BAR IN THE SWITCH. WHERE SPECIAL PERMISSION IS GRANTED, THE NEUTRAL LINE MAY BE BROKEN IF THE SOCKET IS EQUIPPED WITH AN APPROVED CONNECTION DEVICE.
- G. ALL METER SOCKETS SHALL BE RING TYPE.

WYE METER REQUIREMENTS				
TYPE OF SERVICE	REF. PAGE NO.	MAIN SIZE (AMPS)	METER	METER SOCKET
2W-1 PHASE 120V	C-11	0-100	CL. 100 120V 2W 1 PHASE (A)	100A 4 POINT
3W-1 PHASE 120/208V	C-11	0-200	CL. 200 120V 3W 1 PHASE	100A-200A 5 POINT

DELTA METER REQUIREMENTS				
TYPE OF SERVICE	REF. PAGE NO.	MAIN SIZE (AMPS)	METER	METER SOCKET
2W-1 PHASE 120V	C-11	0-100	CL. 100 120V 2W 1 PHASE (A)	100A 4 POINT
3W-1 PHASE 120/240V	C-11	0-125	CL. 200 240V 3W 1 PHASE	100A 4 POINT
3W-1 PHASE 120/240V	C-11	126-200	CL. 200 240V 3W 1 PHASE	200A 4 POINT
3W-1 PHASE 120/240V	D-5, D-6	400 (MAX)	CL. 320 240V 3W 1 PHASE	400A (MAX) CL. 320 4 POINT

NOTES:

(A) DEPENDING ON MANUFACTURER, METER IS RATED CL. 100 OR CL. 200.



ESR: T003

ESR PG. NO.: C-12

REV. DATE: OCTOBER 2024  
REV. NO.: 7

RESIDENTIAL METER REQUIREMENTS

STANDARD NO.:

---



CONDUCTOR REQUIREMENTS		
MAIN SIZE	0-100 FT	101-300 FT
0-125A (I)	2-2/0 & 1-1/0 AL	2-4/0 & 1-2/0 AL
200A (I)	2-2/0 & 1#1AWG AL	2-4/0 & 1-2/0 AL
201A-400A	2-4/0 & 1-2/0 AL	2-350 MCM & 1-4/0 AL
IF EXCEEDING 200A CONTACT SMUD'S LINE DESIGN DEPARTMENT AT 732-5700		

**NOTES:**

- A. SMUD MUST INSPECT SERVICE TRENCH AND CONDUIT INSTALLATION BEFORE SERVICE CAN BE CONNECTED. TO SCHEDULE AN INSPECTION CALL SMUD'S LINE SCHEDULING DEPARTMENT AT 732-5990. SERVICE INSPECTION WILL BE COMPLETED WITHIN 48 HOURS OF NOTIFICATION OF INSTALLATION WHEN POSSIBLE.
- B. CUSTOMER MAY BACKFILL AFTER 5 (FIVE) FULL WORKING DAYS OF NOTIFYING SMUD'S T & D LINE DESIGN DEPARTMENT THAT SERVICE IS READY FOR INSPECTION. IF NO DEFICIENCY NOTICE IS POSTED BY SMUD (DEFICIENCY NOTICES WILL BE POSTED ON PANEL OR HOUSE END OF CONDUIT) WITH THE UNDERSTANDING THAT THE CUSTOMER WILL BE HELD RESPONSIBLE FOR CORRECTIONS REQUIRED.
- C. SMUD MAY REQUIRE SERVICE CONDUIT TO BE POTHOLED BY CUSTOMER IF BACKFILLED PRIOR TO INSPECTION.
- D. BOXES REQUIRING CUSTOMER ACCESS TO PERFORM WORK WILL BE OPENED EACH DAY AS NECESSARY BY SMUD AND CLOSED AT THE END OF EACH DAY. UNAUTHORIZED ENTRY INTO THE BOX BY THE CUSTOMER IS PROHIBITED.
- E. SMUD WILL MAKE ALL TERMINATIONS OF SERVICE CABLE AT SERVICE POINT. CUSTOMER IS TO MAKE ALL TERMINATIONS AT PANEL, IN ACCORDANCE WITH ALL LOCAL ELECTRICAL CODES.
- F. ALL SERVICE POINT LOCATIONS TO BE WITHIN 4" OF FINAL GRADE BEFORE SERVICE WILL BE PROVIDED.
- G. CONDUCTOR MUST BE APPROVED BY SMUD'S LINE DESIGN DEPARTMENT AND MUST CONFORM TO APPENDIX A - SMUD'S TECHNICAL STANDARDS DEPARTMENT SPECIFICATION NO. DS1004 (FORMERLY D004), 600 VOLT, ALUMINUM SINGLE CONDUCTOR POWER CABLE. SEE C-3, C-4, C-5 & C-14 FOR TRENCH AND CONDUIT SPECIFICATIONS.
- H. SEE C-3, C-4, C-5 & C-14 FOR TRENCH AND CONDUIT SPECIFICATIONS.
- I. SEE UAD0.6 FOR MAX CABLE RUNS NOT TO EXCEED VOLTAGE FLICKER REQUIREMENTS.



**ESR: T003**

**ESR PG. NO.: C-13**

REV. DATE: OCTOBER 2024    REV. NO.: 7

**SMUD ELECTRICAL SERVICE REQUIREMENTS FOR  
CUSTOMER RUN SERVICE TO RESIDENTIAL SUBDIVISION,  
SINGLE FAMILY THROUGH SIXPLEX DWELLINGS**

STANDARD NO.:

---

PAGE 1 OF 1

**CUSTOMER INSTALLED SERVICE WHERE SMUD SECONDARY BOX PRESENT**

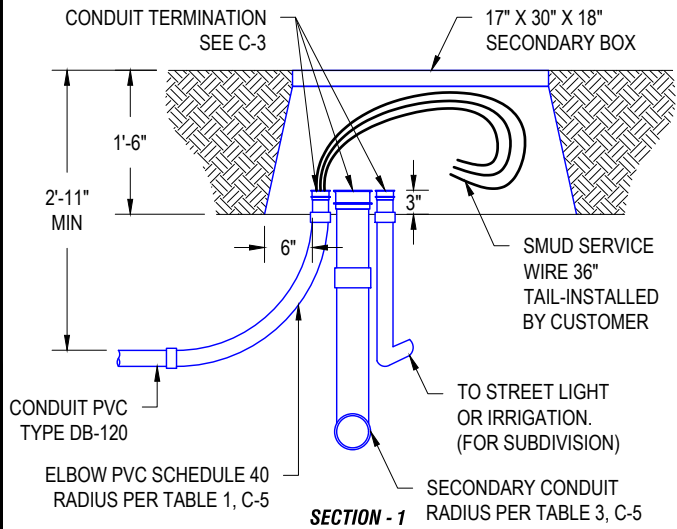
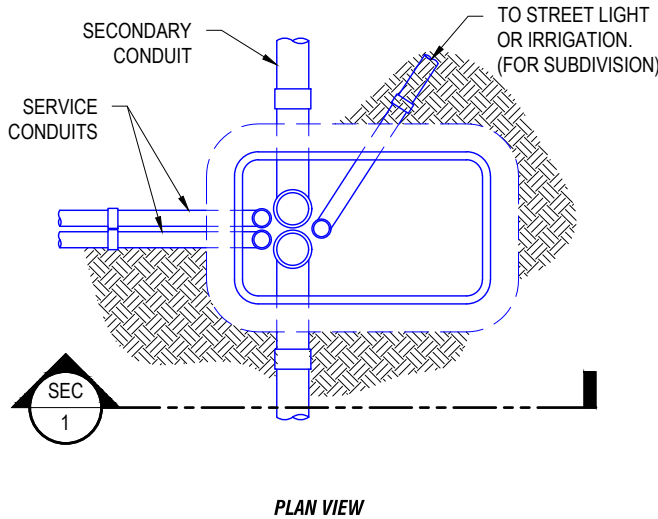

**FOUNDATION HOUSE SERVICE OPTIONS**

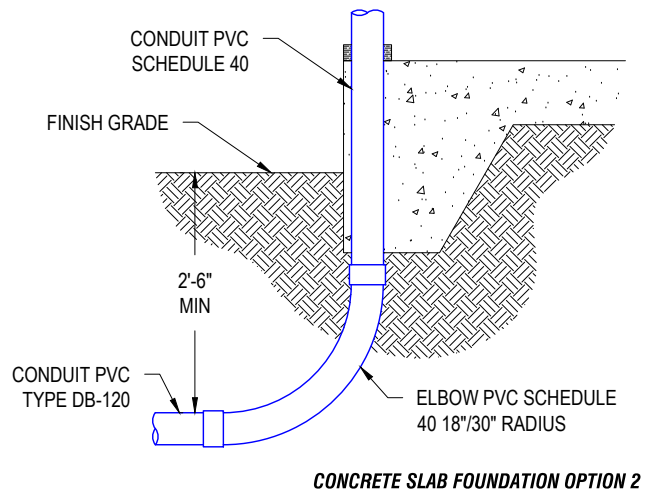
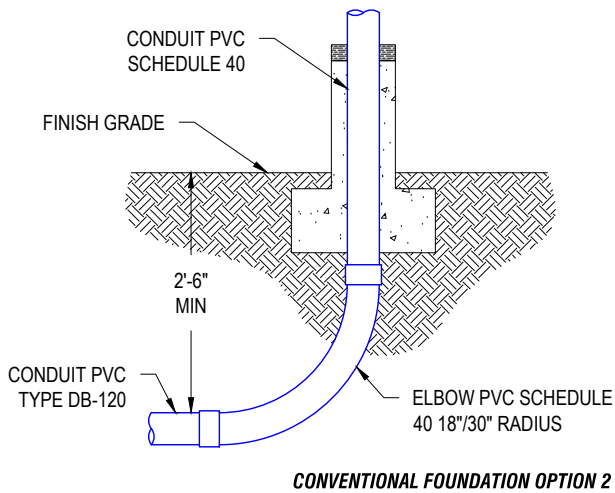
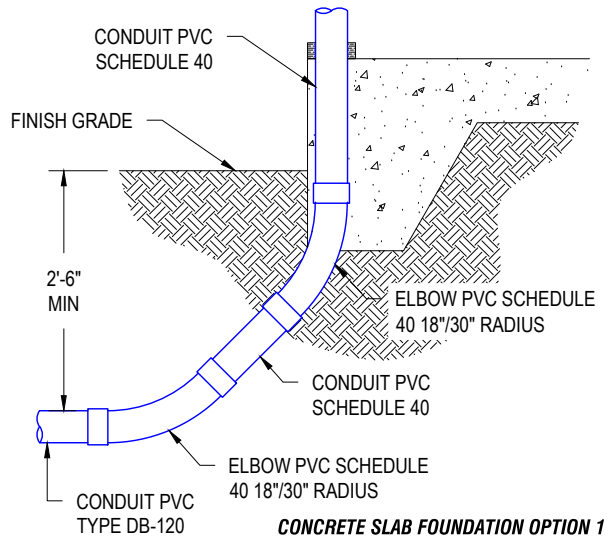
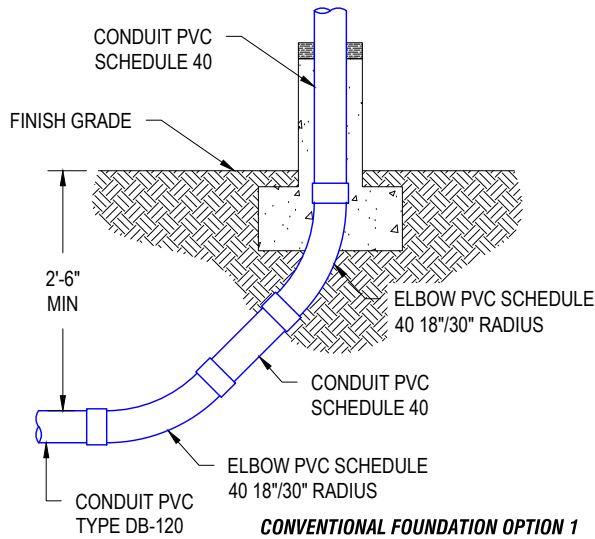

ESR: T003

ESR PG. NO.: C-14

REV. DATE: OCTOBER 2024  
REV. NO.: 7

**CUSTOMER INSTALLED SERVICE  
WHERE SMUD SECONDARY BOX IS PRESENT  
& FOUNDATION HOUSE SERVICE**

STANDARD NO.:

---

PAGE 1 OF 1

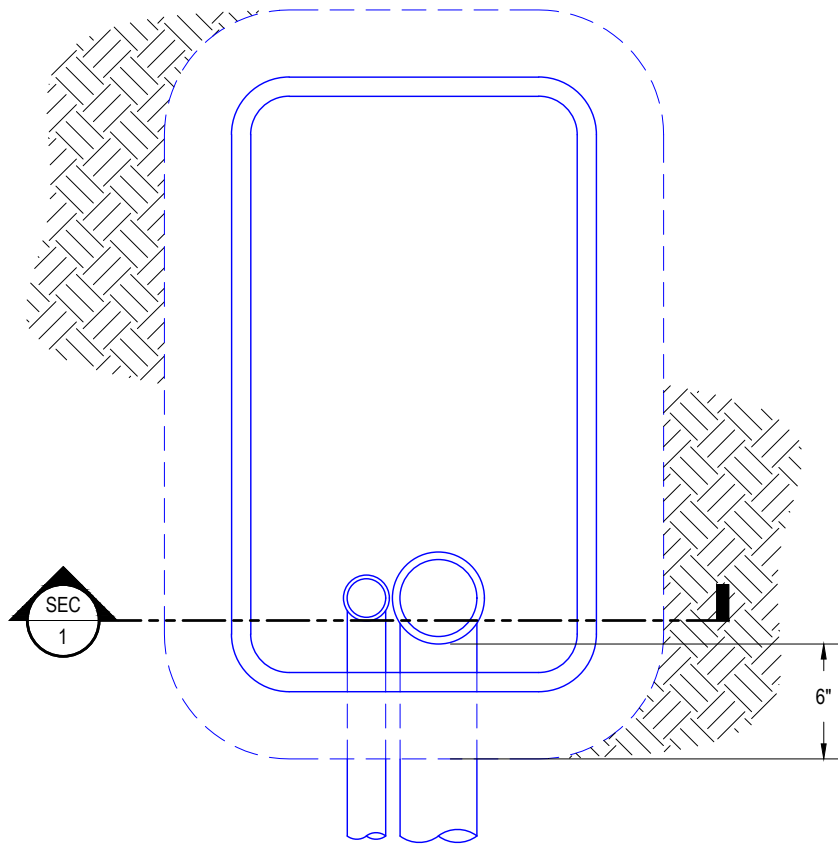

PLAN VIEW

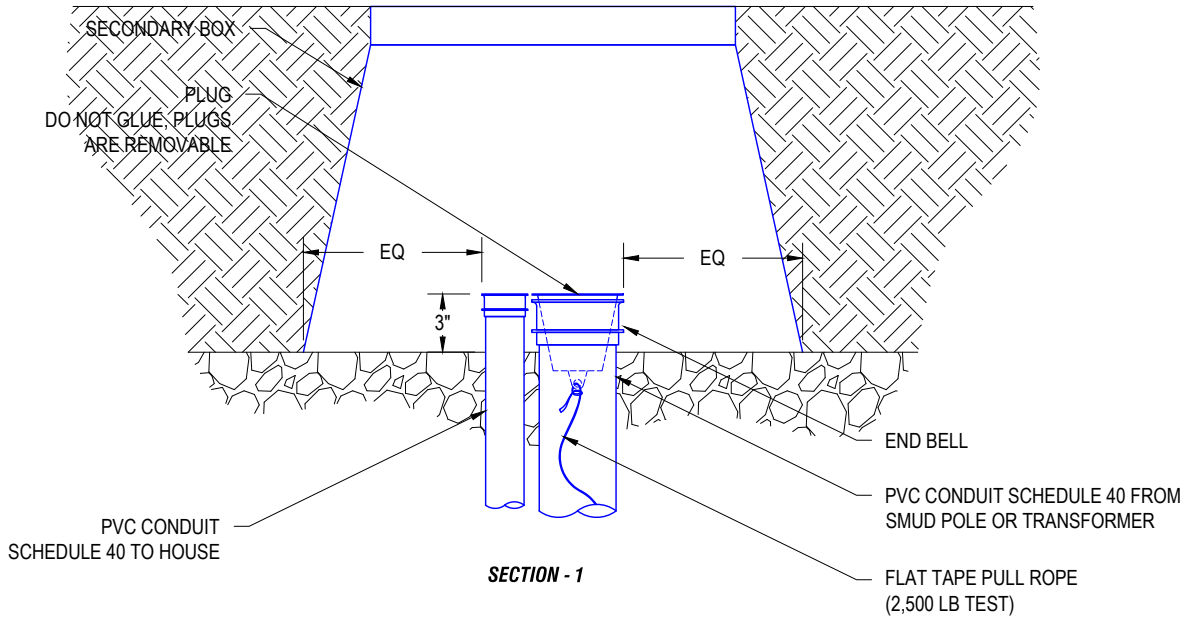

SECTION - 1



ESR: T003

ESR PG. NO.: C-15

REV. DATE: OCTOBER 2024  
REV. NO.: 7

SECONDARY BOX  
DETAIL TYPICAL CONDUIT TERMINATION

STANDARD NO.:

---

**A. SERVICE UPGRADE:**

1. AN INCREASE IN THE AMPACITY RATING (E.G., 100 AMPS TO 125 AMPS) OF THE EQUIPMENT WHERE SMUD TERMINATES ITS SERVICE IS TYPICALLY DEFINED AS AN UPGRADE. THE AMPACITY RATING ALSO MAY BE KNOWN AS THE SERVICE-ENTRANCE CAPACITY. FOR EXAMPLE, WHEN A CUSTOMER REPLACES AN EXISTING ELECTRIC METER PANEL, SWITCHBOARD, OR TERMINATION ENCLOSURE WITH ONE THAT HAS A GREATER AMPACITY RATING (I.E., UPGRADE), ALL SMUD T003 ELECTRIC SERVICE REQUIREMENTS MUST BE MET. TYPICALLY, THIS ALSO INCLUDES INSTALLING NEW CONDUIT AND SERVICE CONDUCTORS. CONDUIT OR CONDUCTOR MAY NOT REQUIRE UPGRADING, AS DETERMINED BY SMUD.
2. FOR UPGRADED PANELS WHERE THE NEW SPECIFIED SIZE OF SERVICE CONDUCTOR WILL FIT IN THE EXISTING CONDUIT, IT IS NOT NECESSARY TO UPGRADE THE CONDUIT TO THE CURRENTLY SPECIFIED SIZE FOR THE NEW PANEL IF THE FOLLOWING ARE MET:
  - 2.1 THE MAXIMUM FILL RATIO IS NOT EXCEEDED
  - 2.2 THE CALCULATED CABLE PULLING TENSIONS ALONG THE CONDUIT ROUTE ARE WITHIN LIMITS OF THE NEW CABLE
3. IF THE NEW PANEL CAN ACCOMMODATE IT, THE EXISTING SERVICE CONDUCTOR MAY BE REUSED PROVIDED IT MEETS THE VOLTAGE DROP, AND FLICKER REQUIREMENTS OF THE NEW LOAD. IF THE SERVICE CONDUCTOR SIZE MUST BE UPGRADED, CURRENT CONDUIT REQUIREMENTS SHALL BE MET.
4. IN THE UNLIKELY EVENT THAT SMUD CREWS ARE UNABLE TO REMOVE AND REPLACE THE EXISTING ELECTRICAL CONDUCTORS WITHIN THE EXISTING CONDUIT, IT WILL BE THE CUSTOMERS RESPONSIBILITY TO REPLACE THE EXISTING SERVICE SYSTEM PER SMUD'S CURRENT RULES, REGULATIONS, POLICIES AND PROCEDURES SET FORTH IN THE SMUD T003 ELECTRIC SERVICE REQUIREMENT.
5. DIRECT BURIED SERVICE CONDUCTOR NEEDS TO BE REPLACED WITH APPROVED SERVICE CABLE AND INSTALLED IN APPROVED SERVICE CONDUIT

**B. SERVICE REPLACEMENT (LIKE-FOR-LIKE):**

1. REPLACING SERVICE EQUIPMENT WITH EQUIPMENT OF THE EXACT SAME AMPACITY (E.G., 100 AMPS TO 100 AMPS) IS CONSIDERED "LIKE-FOR-LIKE" REPLACEMENT AND TYPICALLY NOT CONSIDERED AN UPGRADE.
2. THE SERVICE EQUIPMENT MUST BE POSITIONED SO THE EXISTING SMUD SERVICE CONDUCTORS CAN BE RECONNECTED PROPERLY. A LIKE-FOR-LIKE DOES NOT HAVE TO MEET ALL THE CURRENT SMUD T003 ELECTRIC SERVICE REQUIREMENTS IF THE SAFETY OR ACCESSIBILITY OF THE PANEL LOCATION IS NOT COMPROMISED. FOR EXAMPLE, PANELS WITH STRUCTURES (E.G., DECKS, REMODELED BUILDINGS) BUILT OVER OR AROUND THE EXISTING LOCATION MAY NOT BE ENERGIZED IF THEY DO NOT MEET SMUD REQUIREMENTS FOR SAFE WORKING CLEARANCES AND CONDITIONS.
3. IF THE NEW PANEL CAN ACCOMMODATE IT, THE EXISTING SERVICE CONDUCTOR (IN CONDUIT OR DIRECT BURIED) MAY BE REUSED PROVIDED IT MEETS THE VOLTAGE DROP, AND FLICKER REQUIREMENTS OF THE LOAD. IF THE SERVICE CONDUCTOR SIZE MUST BE UPGRADED, CURRENT CONDUIT REQUIREMENTS SHALL BE MET PER SMUD'S CURRENT RULES, REGULATIONS, POLICIES AND PROCEDURES SET FORTH IN THE SMUD T003 ELECTRIC SERVICE REQUIREMENT.
4. IN THE UNLIKELY EVENT THAT SMUD CREWS ARE UNABLE TO REMOVE AND REPLACE THE EXISTING ELECTRICAL CONDUCTORS WITHIN THE EXISTING CONDUIT, IT WILL BE THE CUSTOMERS RESPONSIBILITY TO REPLACE THE EXISTING SERVICE SYSTEM PER SMUD'S CURRENT RULES, REGULATIONS, POLICIES AND PROCEDURES SET FORTH IN THE SMUD T003 ELECTRIC SERVICE REQUIREMENT.
5. ADDITIONAL INFRASTRUCTURE (SERVICE BOX, CONDUIT, TRENCHING) MAY NOT BE REQUIRED IF SECTION 2.1.1 AND 2.1.2 ARE MET.
6. PLEASE NOTE THAT REUSING THE EXISTING SERVICE CONDUCTOR FOR A LIKE-FOR-LIKE PANEL REPLACEMENT COULD CAUSE LOSS OF POWER AND EXTENDED SERVICE OUTAGES FOR YOUR RESIDENCE WHEN ASSOCIATED WITH FAILING CONDUCTORS. IN THE ABSENCE OF INSTALLING A CONDUIT SYSTEM, SMUD WILL ONLY REPAIR (AND NOT REPLACE) YOUR SERVICE CONDUCTORS IF FAILURES OCCUR.

**C. SERVICE RELOCATION:**

1. WHEN EXISTING ELECTRIC FACILITIES ARE RELOCATED, CUSTOMERS MUST MEET ALL CURRENT SMUD T003 ELECTRIC SERVICE REQUIREMENTS. IF SMUD'S EXISTING SERVICE CONDUCTOR CAN BE USED, AS DETERMINED BY SMUD, THE PANEL MUST BE POSITIONED SO THE SERVICE CONDUCTOR CAN BE RECONNECTED PROPERLY. THE EXISTING SERVICE CONDUCTOR MUST BE ABLE TO BE RECONNECTED TO THE UNDERGROUND ELECTRICAL PANEL TERMINATIONS LUGS **WITHOUT** CABLE TERMINATION TECHNIQUES USING PIN ADAPTORS, CABLE TINGING, OR SPLICING ON ADDITIONAL CABLE.



**ESR: T003**

**ESR PG. NO.: C-16**

REV. DATE: OCTOBER 2024    REV. NO.: 7

**SERVICE PANEL:  
UPGRADING, REPLACING, RELOCATING ELECTRIC  
FACILITIES FOR SINGLE-PHASE 120V SERVICE**

STANDARD NO.:

---

PAGE 1 OF 1

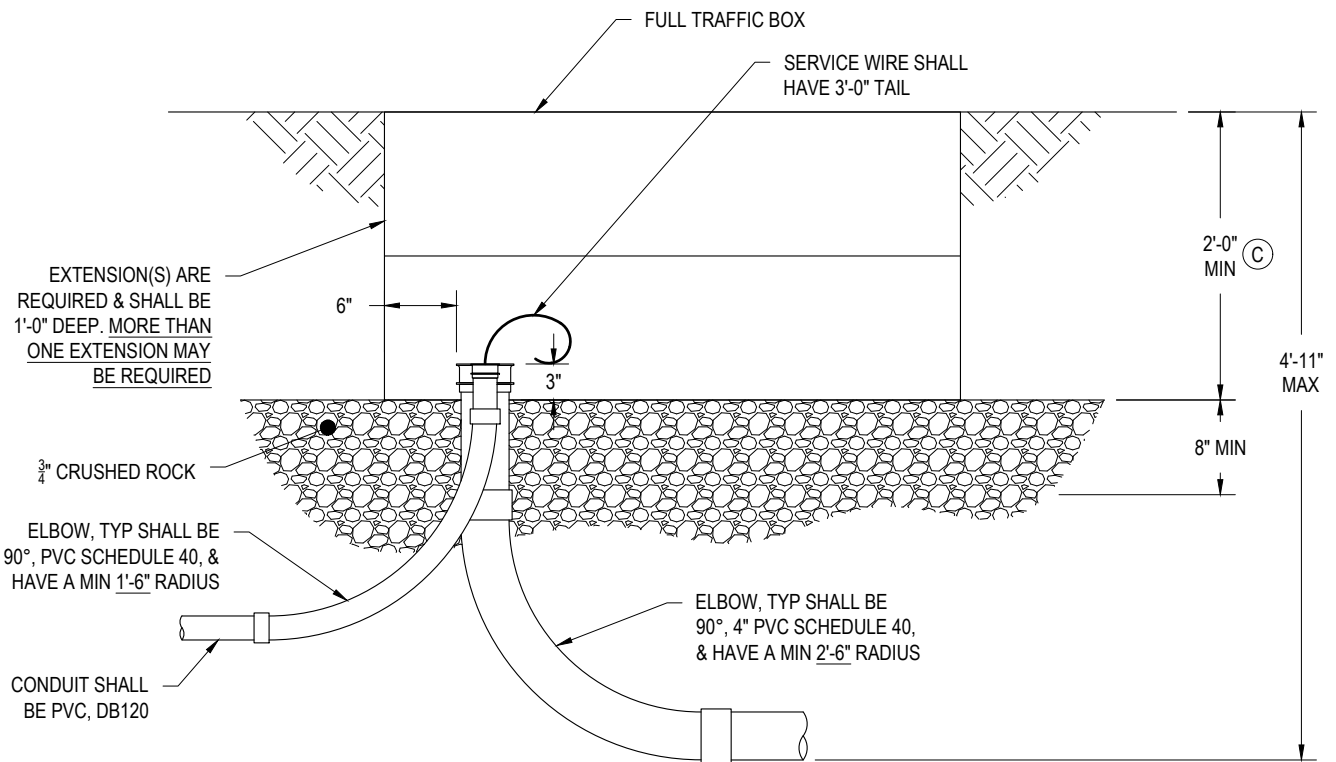

**TABLE - 1**

MINIMUM ELBOW RADIUS FOR ALL SERVICE CONDUIT ELBOWS (11¼°, 22½°, 45° & 90°)	
CONDUIT SIZE	RADIUS
2"-3"	1'-6"
4"	2'-6"

**SECONDARY INSTALLATION**

**NOTES:**

- A. FULL TRAFFIC BOXES SHALL BE INSTALLED IN FULL TRAFFIC LOCATIONS & INCIDENTAL TRAFFIC LOCATIONS SUCH AS PARKING LOTS, ALLEYS, & INDUSTRIAL AREAS.
- B. TRAFFIC BOXES REQUIRE A BASE OF AN EIGHT (8) INCH LAYER OF ¾" CRUSHED ROCK. THE CRUSHED ROCK SHALL BE
- C. TAMPED & CONSOLIDATED.
- D. MAXIMUM DEPTH DEPENDS ON MANUFACTURER. THE MAX DEPTH FOR COMPONENTS PROVIDED BY JENSEN IS 3'-0".
- E. MINIMUM CONDUIT COVER WILL DEPEND ON CONDUIT SIZE.



ESR: T003

ESR PG. NO.: C-17

REV. DATE: OCTOBER 2024  
REV. NO.: 10

INSTALLATION FOR  
17" X 30" & 24" X 36"  
FULL TRAFFIC BOXES

STANDARD NO.:  
**U1S3X4**

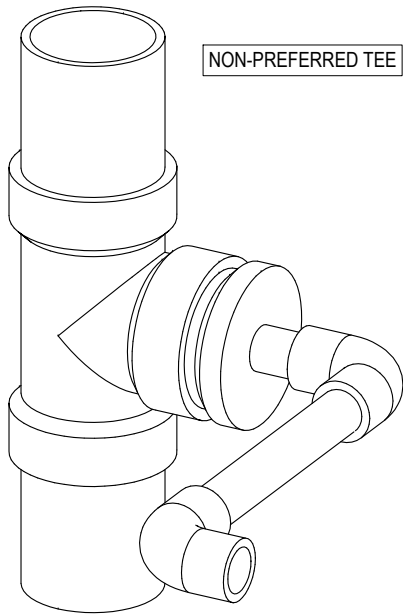

NON-PREFERRED TEE

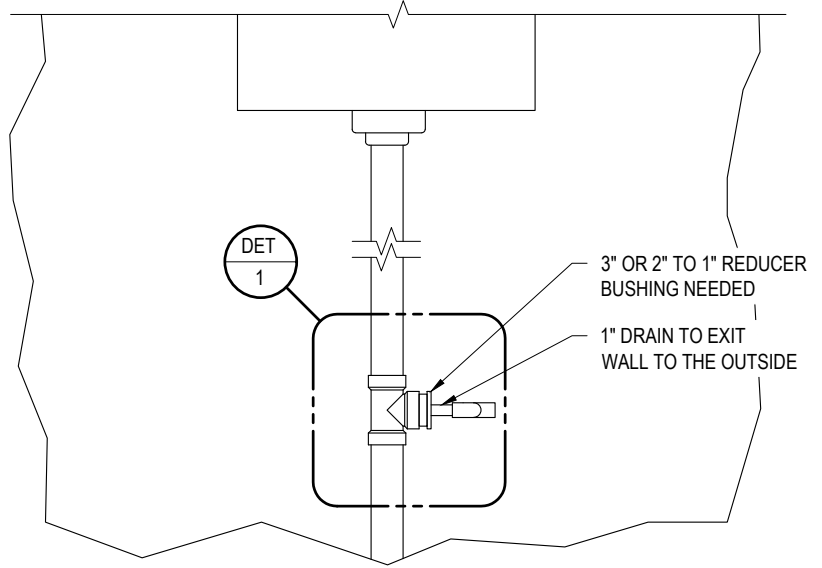

SECTION - 1

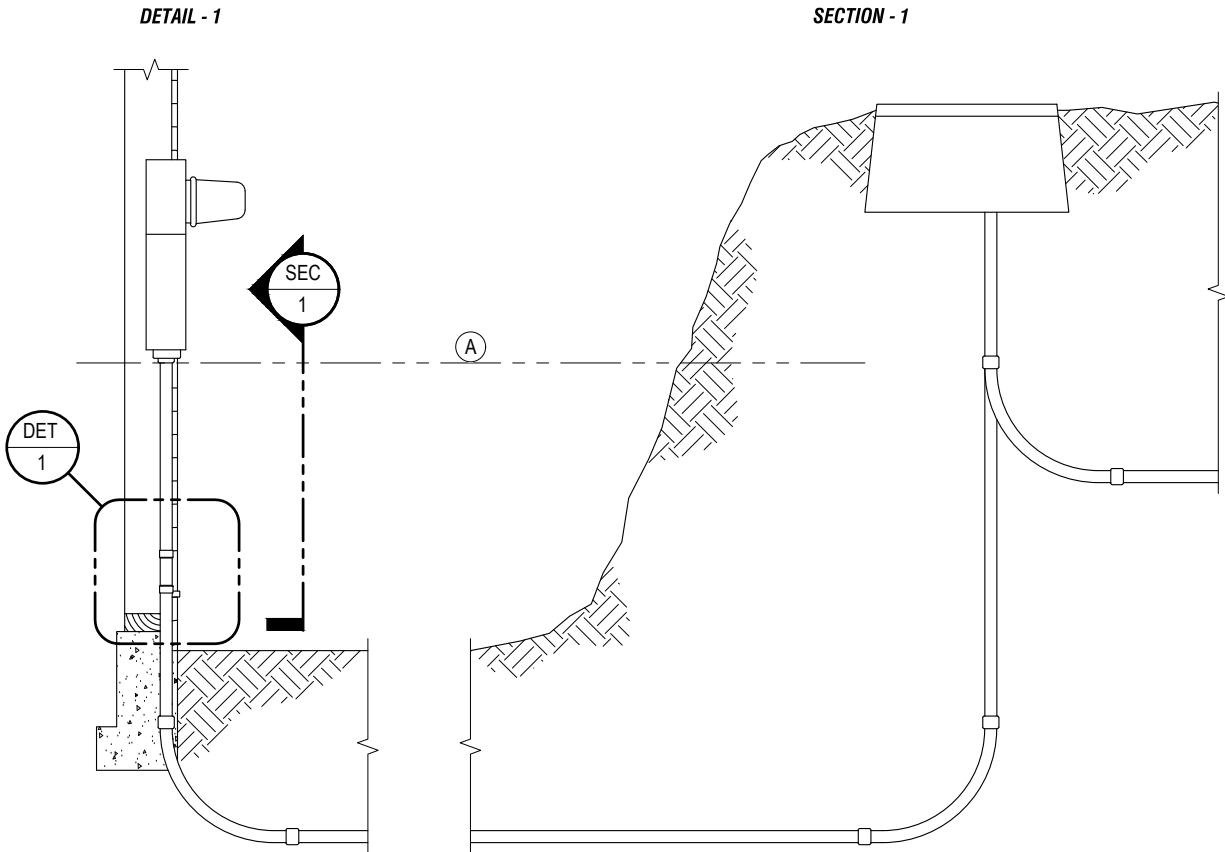

DETAIL - 1

NOTES:

- A. WHEN THE SECONDARY SERVICE BOX IS ELEVATED ABOVE THE BOTTOM OF THE METER PANEL, A DRAIN SHALL BE INSTALLED BETWEEN THE METER PANEL & HOUSE FOUNDATION.
- B. ALL PVC CONNECTIONS SHALL BE GLUED.
- C. "FLO SADDLE," OR EQUIVALENT, IS PREFERRED CONSTRUCTION. PER DETAIL 1, A TEE MAY BE USED INSTEAD. BUT IS NOT PREFERRED.



ESR: T003

ESR PG. NO.: C-18

REV. DATE: OCTOBER 2024  
REV. NO.: 1

CONDUIT DRAIN FOR ELEVATED SERVICE BOX

STANDARD NO.:

---

PAGE 1 OF 1

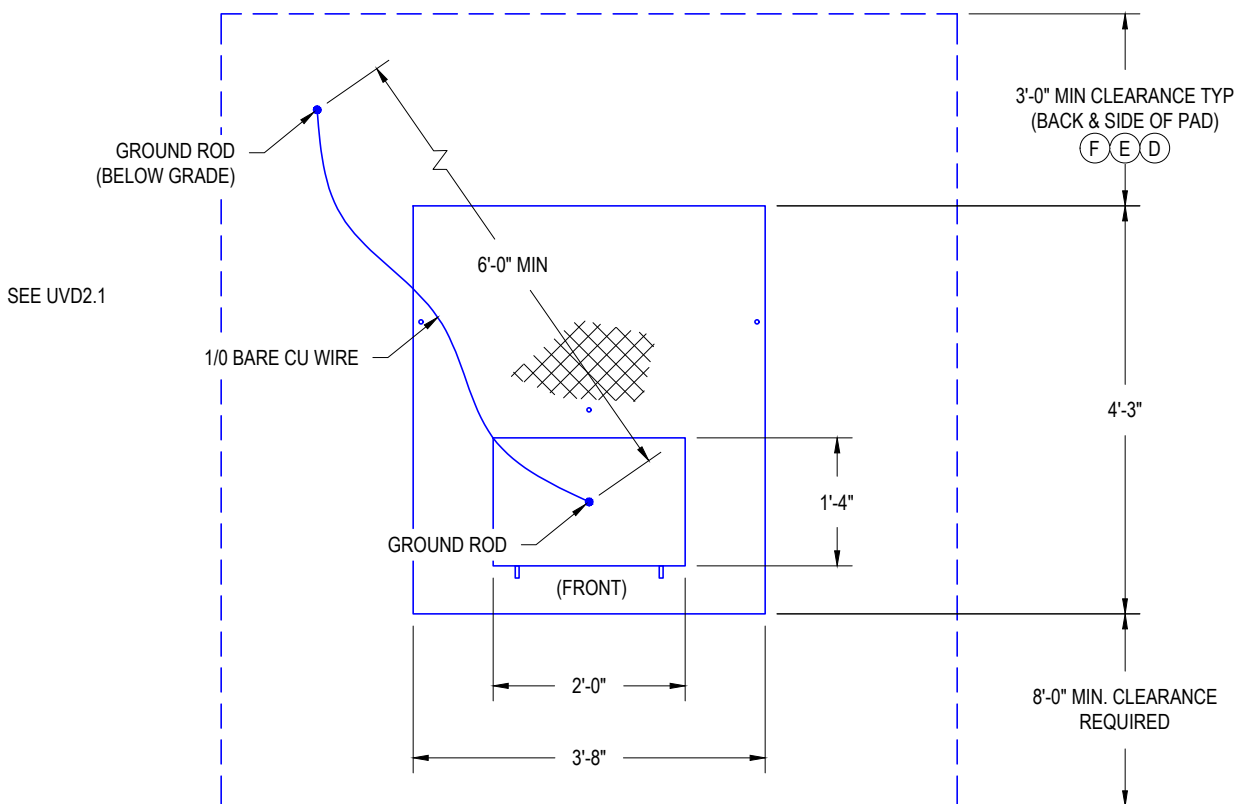

**NOTES:**

- A. TOP SURFACE OF PAD MUST BE LEVEL.
- B. FOR P.U.E & TRENCH INFORMATION SEE DWG. U12K3X1, "SINGLE PHASE TRANSFORMER PAD & WELL INSTALLATION".
- C. THE PAD FRONT SHALL HAVE A CLEARANCE OF NOT LESS THAN 8'-0" FROM OBJECTS OR STRUCTURES.
- (D) THE TRANSFORMER PAD SHALL BE SO LOCATED THAT THE PAD SIDE OR SIDES ADJACENT TO THE SURFACE OF A BUILDING SHALL HAVE A CLEARANCE OF NOT LESS THAN 3'-0". THIS CLEARANCE MAY BE REDUCED TO 2'-0" IF THE BUILDING SURFACE IS NONCOMBUSTIBLE. THE CLEARANCE SHALL BE NO LESS THAN 8'-0" FROM ALL TREES.
- (E) WHERE THE TRANSFORMER MAY BE LESS THAN 5'-0" FROM VEHICULAR TRAFFIC, PROTECTIVE CHAIN LINK FENCE OR BOLLARDS SHALL BE INSTALLED PER SMUD ENGINEERING DRAWINGS UVD2.4 & UVD2.5. ALL CLEARANCES ARE TO BE APPROVED BY SMUD'S DISTRIBUTION LINE DESIGN DEPARTMENT.
- (F) ANY EXISTING OR PROPOSED SWITCHGEAR OR ELECTRICAL EQUIPMENT MUST PROVIDE NATIONAL ELECTRICAL CODE CLEARANCES FROM THE TRANSFORMER & PAD.
- G. EXPANSION JOINTS SHALL BE INSTALLED BETWEEN THE CONCRETE TRANSFORMER PAD & ADJACENT CONCRETE WALKWAYS, DRIVEWAYS, ETC.
- H. SECOND GROUND ROD SHALL BE INSTALLED PER REQUIREMENTS IN T007. ROD SHALL BE INSTALLED BEYOND THE BACK OF THE PAD. IF PAD BACKS UP TO THE EDGE OF THE PUE THE ROD SHALL BE PLACED TO THE SIDE BETWEEN THE TRENCH & PUE EDGE. THE ROD SHALL BE PLACED WITHIN THE PUE OR DEDICATED RIGHT-OF-WAY.

**PLAN VIEW**

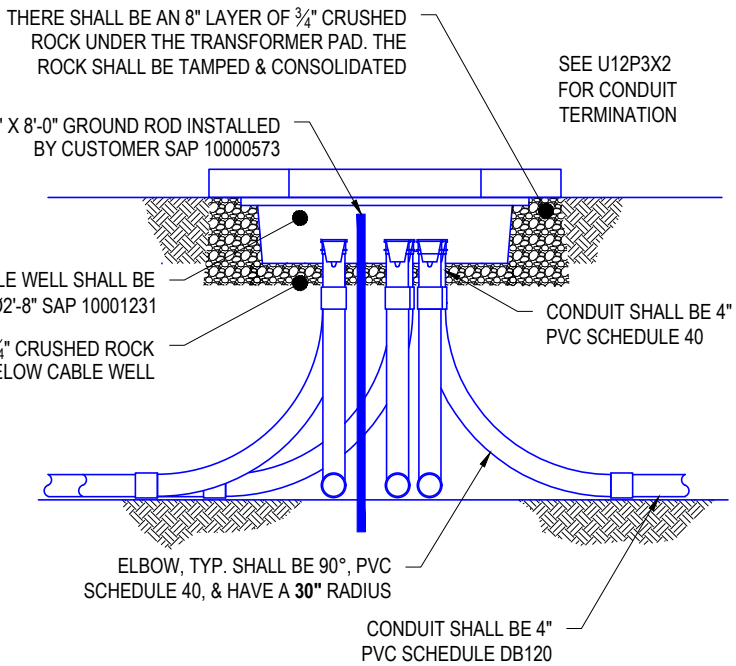

**SECTION VIEW**

 Sacramento Municipal Utility District	<b>ESR: T007, T003</b>	<b>ESR PG. NO.: C-34, C-19</b>	REV. DATE: MARCH 2023 REV. NO.: 3
	<b>SINGLE PHASE TRANSFORMER          PAD INSTALLATION 44" X 51"</b>		<b>STANDARD NO.:</b> <b>UVD2.1A</b> PAGE 1 OF 1

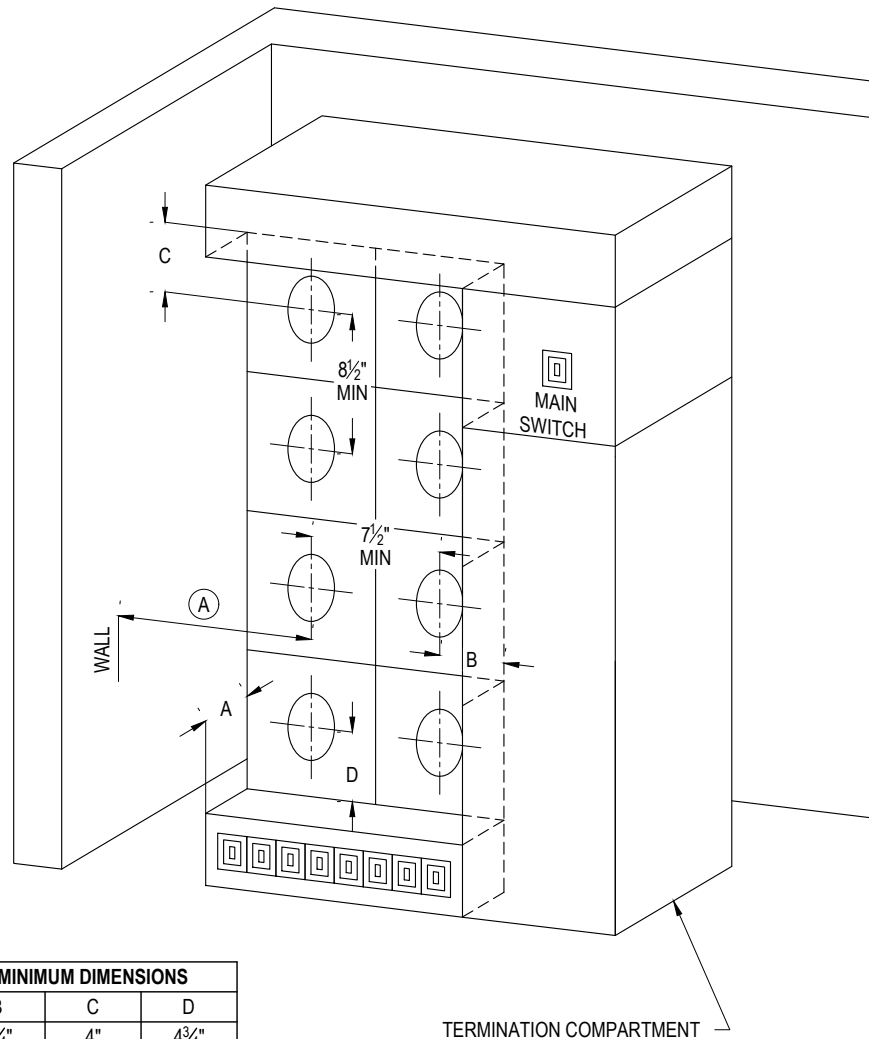

TABLE 1		MINIMUM DIMENSIONS		
A (PROTRUSIONS)	B	C	D	
0 (NO PROTRUSIONS)	3 3/4"	4"	4 3/4"	
0" TO 1 1/8"	4 1/4"	4"	4 3/4"	
1 1/8" TO 2"	4 1/4"	4 1/4"	6 1/4"	
2" TO 4"	6 1/4"	4 1/4"	8"	
4" TO 11" MAX	6 1/4"	10"	8"	

**NOTES:**

- A. WHERE AN ADJACENT WALL OR OTHER OBSTRUCTION EXTENDS MORE THAN 11" PERPENDICULAR FROM THE FACE OF THE METER PANEL, A 10" MIN. DIMENSION TO THE METER SOCKET AXIS IS REQUIRED. FOR OBSTRUCTIONS EXTENDING 11" OR LESS FROM THE METER PANEL, THE SIDE CLEARANCE SHALL CONFORM TO THAT OF DIMENSION "B".
- B. NOT MORE THAN TWO SOCKETS SHALL BE MOUNTED ON ANY REMOVABLE PANEL.
- C. UNDERGROUND LANDING LUGS SHALL NOT BE PLACED UNDER ANY SOCKET COVER.
- D. DIMENSION "B" SHALL BE INCREASED BY THE AMOUNT THAT THE MAIN SWITCH DOOR, INCLUDING OPERATING HANDLE, REDUCES THE CLEARANCE WHEN OPENED 90 DEGREES.
- E. REMOVABLE COVERS SHALL NOT EXCEED 6 SQUARE FEET IN AREA.
- F. DISTRIBUTION CONDUCTORS SHALL BE SEPARATED BY AN APPROVED BARRIER FROM THE METERING COMPARTMENT.
- G. TEST BYPASS DEVICES ARE NOT TO BE INSTALLED ON INDIVIDUAL APARTMENT METERS.
- H. FOR TEST BYPASS REQUIREMENTS ON APARTMENT "HOUSE" METERS, SEE PAGE D-4.
- I. PANEL DESIGN SHALL PERMIT CONVENIENT REPLACEMENT OF ANY INDIVIDUAL METER SOCKET JAW ASSEMBLY.
- J. METER PANELS SHALL BE SEALABLE.
- K. BEFORE USING THESE ARRANGEMENTS ON 3-PHASE, 4-WIRE SERVICES, CONSULT SMUD'S (T&D LINE DESIGN DEPARTMENT).
- L. FOR OUTDOOR INSTALLATIONS, THE MAXIMUM METER HEIGHT IS 6'-3" & THE MINIMUM IS 4'-0". WHEN VERTICALLY STACKED, THE MINIMUM METER HEIGHT MAY BE REDUCED TO 3'-6".
- M. FOR INSTALLATIONS INSIDE A DOUBLE LOCKED CABINET OR METER ROOM, THE MINIMUM METER HEIGHT MAY BE REDUCED TO 3'-0".
- N. SEE EUSERC DRAWING 353.



ESR: T003

ESR PG. NO.: D-1

REV. DATE: OCTOBER 2024  
REV. NO.: 7

TYPICAL RESIDENTIAL MULTIPLE  
METERING INSTALLATION

STANDARD NO.:

---



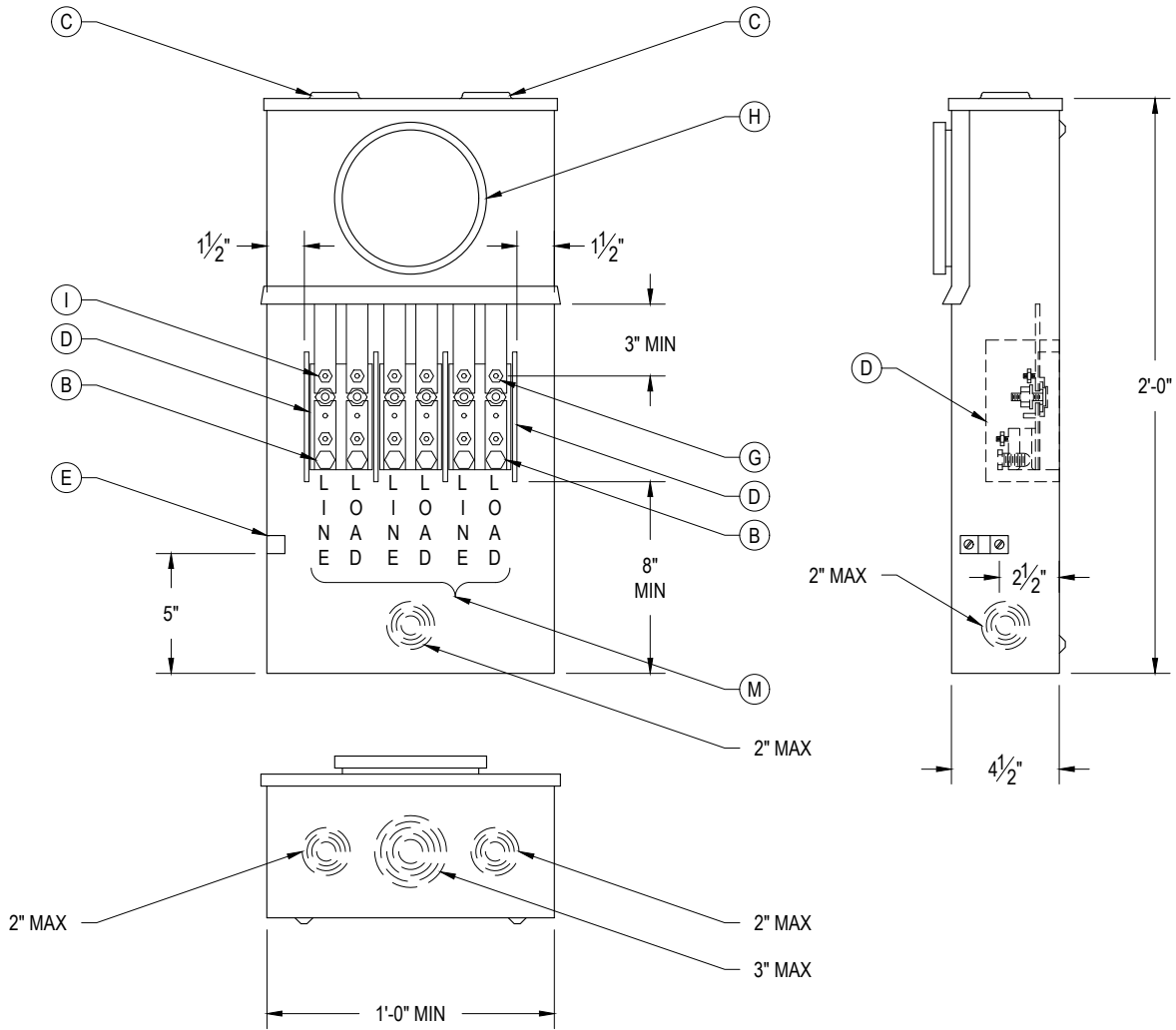

**NOTES:**

- A. SELF-CONTAINED METER SOCKETS SHALL BE UL CURRENT RATED FOR CONTINUOUS DUTY.
- B. ALUMINUM BODIED MECHANICAL LUGS WITH A RANGE OF NO. 6 AWG THROUGH NO. 1/0 AWG.
- C. HUBS MUST BE CAPPED OFF.
- D. RIGID INSULATING BARRIERS MUST BE USED.
- E. INSULATED, BONDABLE VERTICAL LAY-IN, DOUBLE NEUTRAL LUG WITH NO. 1/0 WIRE CAPACITY.
- F. TEST BLOCKS SHALL BE BUSSED OR WIRED TO SOCKET JAWS OR TERMINALS.
- G. UPPER TEST CONNECTOR STUDS.
- H. ALL SECTION COVERS SHALL BE INDEPENDENTLY REMOVABLE. THE UPPER COVER SHALL BE NON-REMOVABLE WHEN THE METER IS IN PLACE. THE LOWER COVER SHALL BE SEALABLE & PERMANENTLY LABELED: "DO NOT BREAK SEALS, NO FUSES INSIDE."
- I. FOR 3Ø, 4 WIRE, CONNECT THE 7TH JAW TO THE BODY OF THE NEUTRAL LUG WITH NO. 8 COPPER WIRE.
- J. FOR 3Ø, 4 WIRE DELTA, IDENTIFY THE RIGHT-HAND TEST BYPASS BLOCK (2 POLES) AS THE POWER LEG.
- K. FOR 1Ø, 3 WIRE, OMIT THE CENTER BLOCK AND ASSOCIATED BARRIERS.
- L. FOR 1Ø, 3 WIRE, 120/208 VOLT, OMIT THE CENTER BLOCK AND ASSOCIATED BARRIERS AND CONNECT THE 5TH JAW TO THE BODY OF THE NEUTRAL LUG WITH NO. 8 COPPER WIRE.
- M. DECALS ON THE INSIDE BACK OF THE ENCLOSURE MUST BE IN 3/4" MINIMUM HIGH BLOCK LETTERS.
- N. TEST BLOCK DETAILS ARE ON PAGE D-4.
- O. SEE EUSERC DRAWING 304.



ESR: T003

ESR PG. NO.: D-2

REV. DATE: OCTOBER 2024  
REV. NO.: 7

**SAFETY SOCKET BOX WITH FACTORY INSTALLED  
TEST BYPASS DEVICES, 100 AMPERES MAXIMUM**

STANDARD NO.:

---

PAGE 1 OF 1

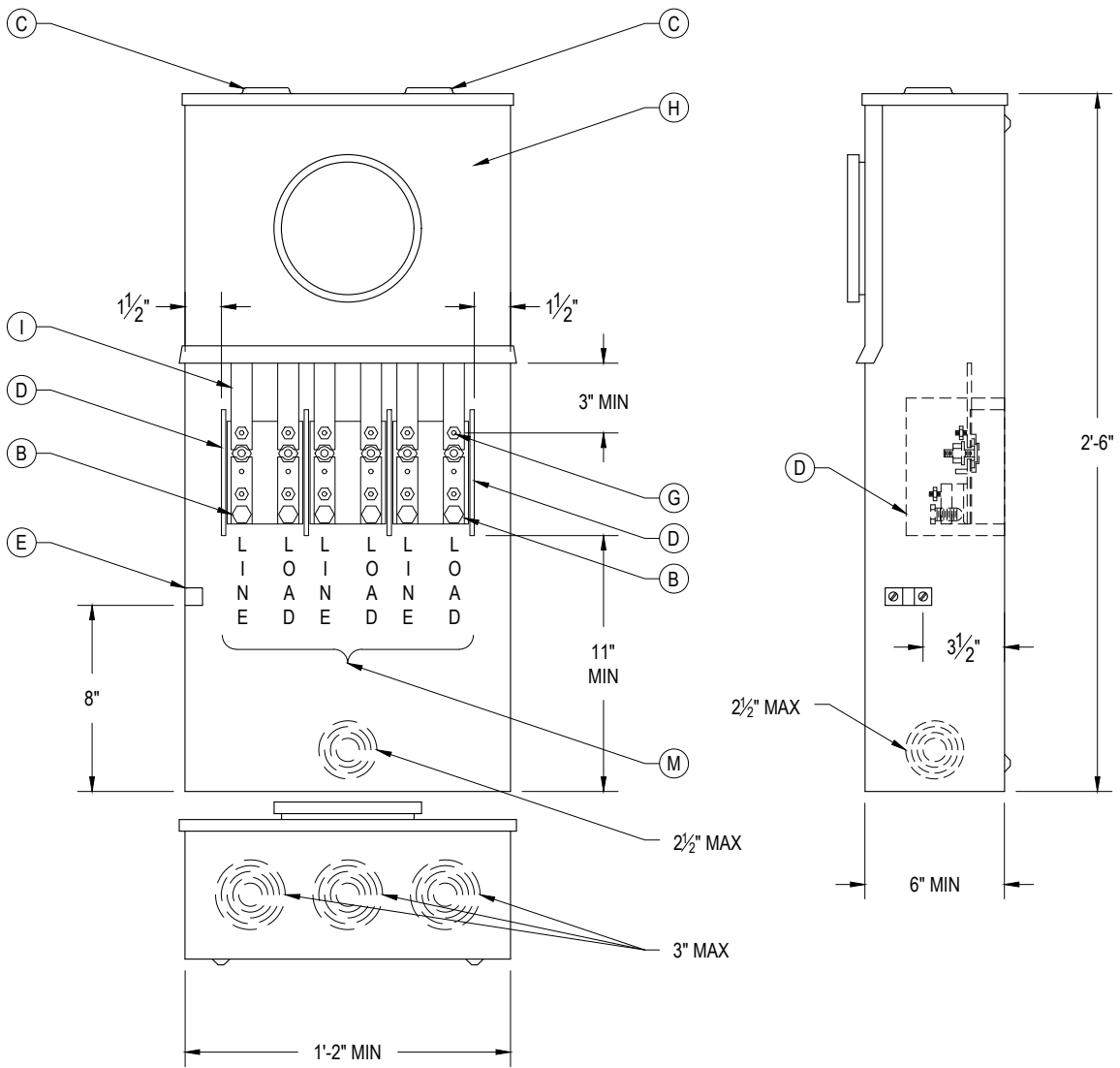

**NOTES:**

- A. SELF-CONTAINED METER SOCKETS SHALL BE UL CURRENT RATED FOR CONTINUOUS DUTY.
- B. ALUMINUM BODIED MECHANICAL LUGS WITH A RANGE OF NO. 1/0 THROUGH NO. 250 MCM WIRE.
- C. HUBS MUST BE CAPPED OFF.
- D. RIGID INSULATING BARRIERS MUST BE USED.
- E. INSULATED, BONDABLE VERTICAL LAY-IN, DOUBLE NEUTRAL LUG WITH NO. 250 MCM WIRE CAPACITY.
- F. TEST BLOCKS SHALL BE BUSSED OR WIRED TO SOCKET JAWS OR TERMINALS.
- G. UPPER TEST CONNECTOR STUDS.
- H. ALL SECTION COVERS SHALL BE INDEPENDENTLY REMOVABLE. THE UPPER COVER SHALL BE NON-REMOVABLE WHEN THE METER IS IN PLACE THE LOWER COVER SHALL BE SEALABLE & PERMANENTLY LABELED: "DO NOT BREAK SEALS, NO FUSES INSIDE."
- I. FOR 3/Ø, 4 WIRE, CONNECT THE 7TH JAW TO THE BODY OF THE NEUTRAL LUG WITH NO. 8 COPPER WIRE.
- J. FOR 3/Ø, 4 WIRE DELTA, IDENTIFY THE RIGHT HAND TEST BYPASS BLOCK (2 POLES) AS THE POWER LEG.
- K. FOR 1/Ø, 3 WIRE, OMIT THE CENTER BLOCK AND ASSOCIATED BARRIERS.
- L. FOR 1/Ø, 3 WIRE, 120/208V, OMIT THE CENTER BLOCK AND ASSOCIATED BARRIERS AND CONNECT THE 5TH JAW TO THE BODY OF THE NEUTRAL LUG WITH NO. 8 COPPER WIRE.
- M. DECALS ON THE INSIDE BACK OF THE ENCLOSURE MUST BE IN 3/4" MINIMUM HIGH BLOCK LETTERS.
- N. TEST BLOCK DETAILS ARE ON PAGE D-4.
- O. SEE EUSERC DRAWING 305.



ESR: T003

ESR PG. NO.: D-3

REV. DATE: OCTOBER 2024  
REV. NO.: 7

**SAFETY SOCKET BOX WITH FACTORY INSTALLED TEST BYPASS DEVICES, 200 AMPERES MAXIMUM**

STANDARD NO.:

---

PAGE 1 OF 1

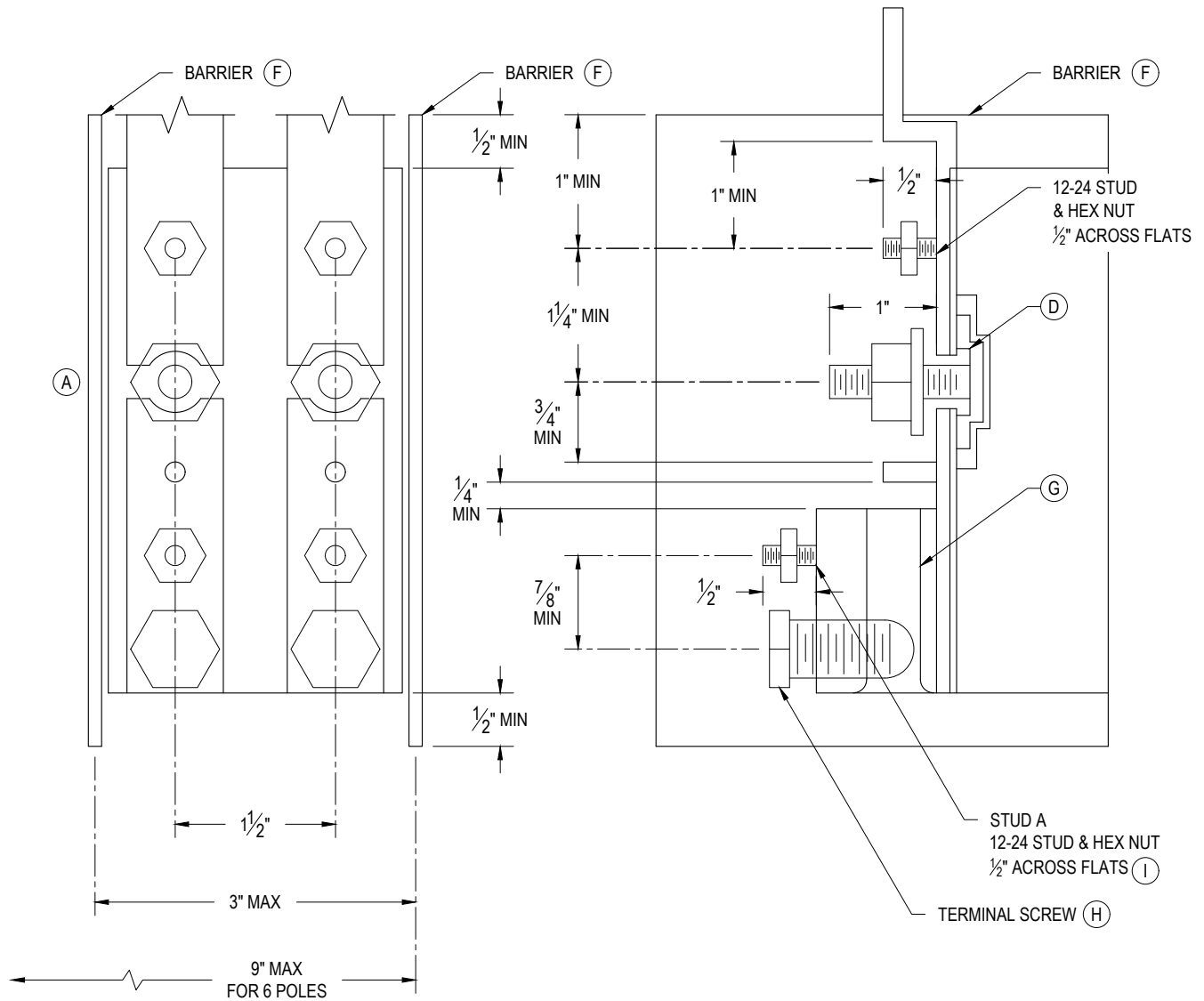

**NOTES:**

- A. THE STRIKE DISTANCE BETWEEN THE UPPER AND LOWER BUS SECTIONS SHALL NOT BE LESS THAN 1/4" WHEN THE SHORTING NUT IS BACKED OFF.
- B. THE CIRCUIT-CLOSING NUT SHALL BE A HEX NUT 5/8" ACROSS FLATS WITH PLATED COPPER WASHER ATTACHED & HAVE THREADS COUNTER-BORED AT THE BOTTOM TO FACILITATE REINSTALLATION. THE BOLT HEAD SHALL BE SECURED IN PLACE TO PREVENT TURNING & BACKOUT.
- C. THE CIRCUIT-CLOSING NUT & BOLT ASSEMBLY SHALL MAINTAIN THE APPLIED CONTACT PRESSURE BETWEEN THE PLATED COPPER WASHER & THE BUS MEMBERS OF THE TEST BYPASS BLOCK.
- D. THE INSULATING WASHER SHALL BE MADE FROM DIMENSIONALLY STABLE, NON-TRACKING MATERIAL & SHALL PROVIDE A MINIMUM OF 1/8" CREEP DISTANCE BETWEEN THE BOLT & THE BUS SECTIONS. BUS SECTIONS SHALL BE PLATED.
- E. WIRE STOPS SHALL EXTEND TO THE CENTER OF THE TERMINAL OPENING OR BEYOND.
- F. RIGID INSULATING BARRIERS SHALL PROJECT AT LEAST 1/4" BEYOND ANY ENERGIZED PARTS WHEN THE MAXIMUM WIRE SIZE IS INSTALLED.
- G. TERMINALS SHALL BE ALUMINUM BODIED. THE OPENING SHALL EXTEND THROUGH THE TERMINAL BODY &, IF THE WIRE HOLE IS ROUND, SHALL BE CHAMFERED AS NECESSARY TO FACILITATE INSTALLATION OF THE LARGEST SIZE WIRE.
- H. THE TERMINAL SCREW MAY BE OF THE ALLEN TYPE (3/16" ACROSS FLATS FOR 100 AMP OR 5/16" ACROSS FLATS FOR 200 AMP). IF STUD "A" IS A PART OF THE TERMINAL SCREW, THE TERMINAL SCREW SHALL BE 5/8" HEX ACROSS FLATS.
- I. STUD "A" SHALL BE LOCATED IN THE CLEAR AREA BETWEEN THE TERMINATING LUG AND THE CIRCUIT-CLOSING NUT AND MAY BE POSITIONED ON THE TERMINAL BODY, ON THE TERMINAL SCREW, ON THE BUS MEMBER, OR INCORPORATED AS PART OF THE WIRE STOP.
- J. SEE EUSERC DRAWING 311.



ESR: T003

ESR PG. NO.: D-4

REV. DATE: OCTOBER 2024  
REV. NO.: 7

**TEST BYPASS BLOCKS FOR  
SAFETY SOCKET, 0-200 AMPERES**

STANDARD NO.:

---

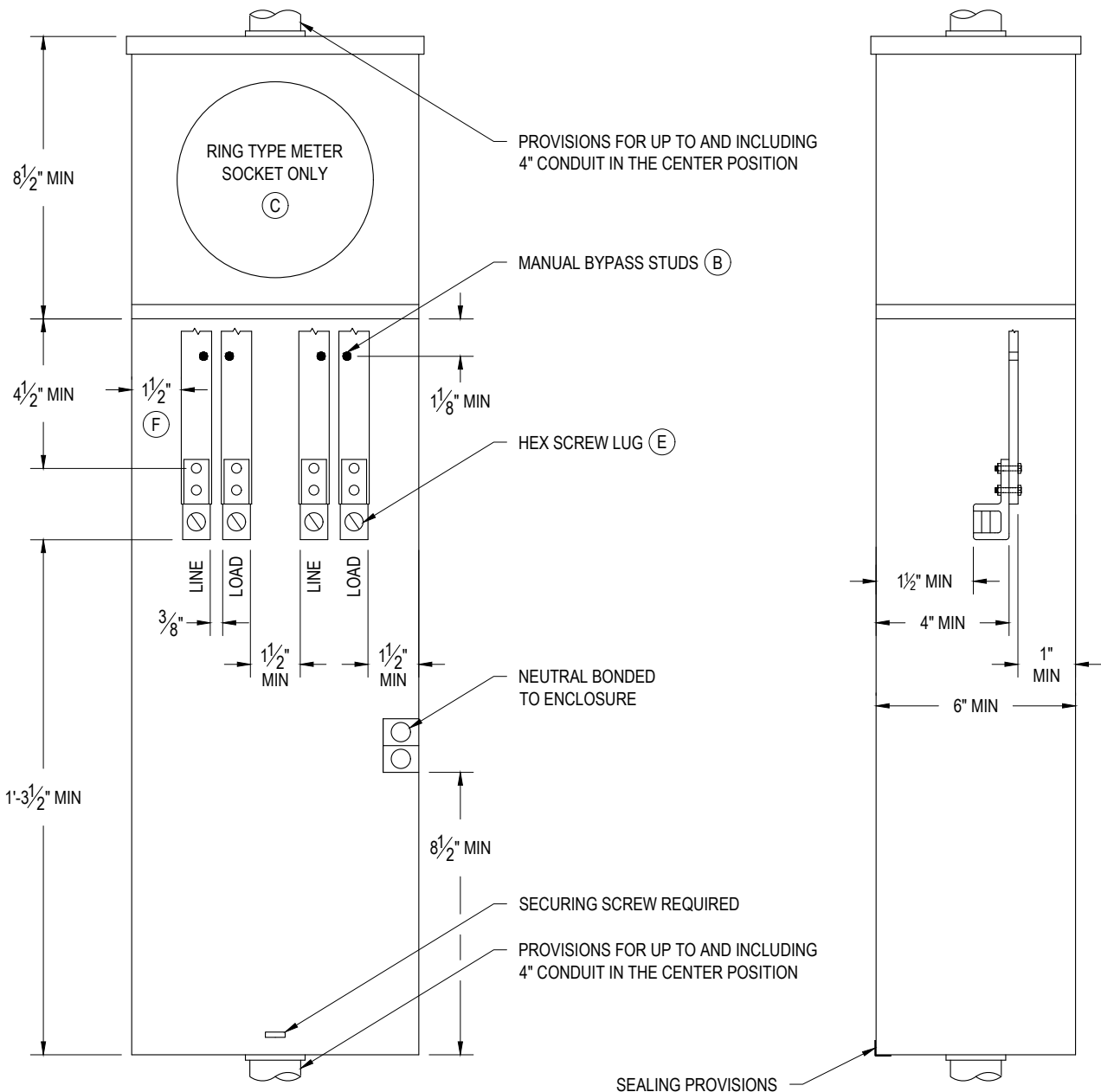

**NOTES:**

- A. THIS SERVICE EQUIPMENT SHALL BE MARKED WITH CONTINUOUS AMPERE RATING OF 320 AMPERES ALTERNATIVELY, IT MAY BE MARKED "400 AMP" (320 AMPERES CONTINUOUS).
- (B). 12-24 BYPASS STUDS,  $\frac{1}{2}$ " IN HEIGHT WITH  $\frac{1}{2}$ " HEX-NUT (MEASURED ACROSS THE FLAT) SHALL BE PROVIDED ON EACH PHASE BUS SECTION. THE STUDS SHALL HAVE A HORIZONTAL SPACING OF  $1\frac{1}{2}$ " (MEASURED FROM THE CENTERS) BETWEEN THE LINE AND LOAD BUS SECTIONS, & SHALL BE OFFSET FROM THE LINE SIDE TERMINATION LUGS TO PERMIT CABLE ENTRY FROM THE TOP WITHOUT INTERFERENCE WITH THE UTILITY PROVIDED MANUAL BYPASS LINKS.
- (C). ON RING TYPE SOCKETS, THE SOCKET METER PANEL SHALL BE PROVIDED WITH A SEALING RING & SHALL NOT BE REMOVABLE WITH METER IN PLACE.
- D. THE BYPASS/CABLE TERMINATION COMPARTMENT COVER PANEL SHALL BE INDEPENDENT OF THE METER PANEL, REMOVABLE, LOCKABLE & SEALABLE.
- (E). TERMINATION FOR SERVICE CONDUCTORS SHALL BE ALUMINUM-BODIED MECHANICAL LUGS WITH A RANGE OF NO. 1 AWG THROUGH 600 KCMIL. THE LUGS SHALL BE SECURED TO ASSURE VERTICAL ALIGNMENT & THE LINE SIDE LUGS SHALL BE OFFSET FROM THE FACE OF THE BUS TO PERMIT CABLE ENTRY FROM THE TOP. THE LINE & LOAD POSITIONS SHALL BE IDENTIFIED IN  $\frac{3}{4}$ " HIGH BLOCK LETTERS.
- (F).  $1\frac{1}{2}$ " DIMENSION MAY BE LESS IF INSULATING MATERIAL IS PROVIDED.
- G. SEE EUSERC DRAWING 302B.

 <p>Sacramento Municipal Utility District</p>	<p><b>ESR: T003</b></p>	<p><b>ESR PG. NO.: D-5</b></p>	<p>REV. DATE: OCTOBER 2024</p>	<p>REV. NO.: 7</p>
	<p><b>400 AMPERE (CLASS 320) RESIDENTIAL METER PANEL WITH MANUAL TEST BYPASS STUDS 120/240 VOLT, SINGLE PHASE 3 WIRE</b></p>		<p>STANDARD NO.:</p> <p>---</p>	<p>PAGE 1 OF 1</p>

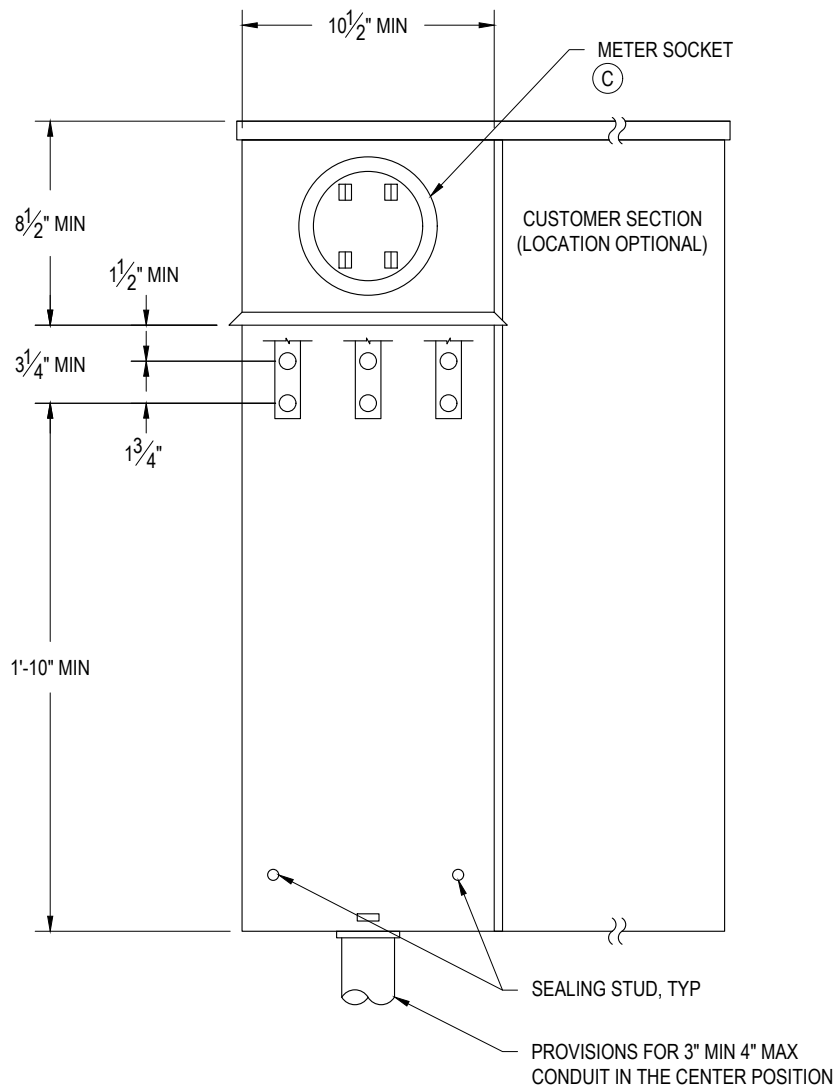

**FRONT VIEW**

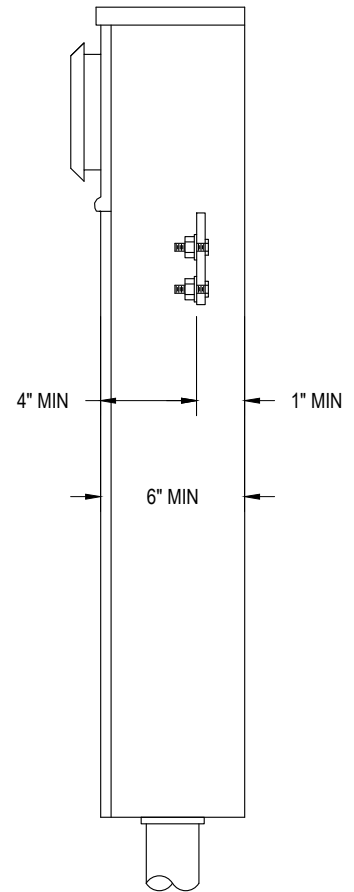

**SIDE VIEW**

**NOTES:**

- A. THE PANEL SHOWN IS A COMBINATION DEVICE HAVING BOTH A UTILITY SECTION (I.E. PULL SECTION & METERING SECTION) & CUSTOMER SECTION, BUT MAY ALSO BE CONSTRUCTED WITHOUT AN ATTACHED CUSTOMER SECTION.
- B. THE PANEL SHALL BE MARKED WITH EITHER A RATING OF "320 AMPERES CONTINUOUS" OR "400 AMPERES MAXIMUM (320 AMPERES CONTINUOUS)".
- C. THE PANEL SHALL BE PROVIDED WITH A SEALING RING & THE METER SOCKET SHALL BE RIGIDLY MOUNTED ON A SUPPORT & ATTACHED TO THE METER PANEL.
- D. SEE EUSERC DRAWING 302A.



**ESR: T003**

**ESR PG. NO.: D-6**

REV. DATE: OCTOBER 2024    REV. NO.: 7

**METER PANEL WITHOUT SOCKET BYPASS FACILITY  
RESIDENTIAL UNDERGROUND SERVICE 400 AMPERES  
(CLASS 320), 120/240 VOLTS, 1 PHASE 3 WIRE**

STANDARD NO.:

---